

**Village of Somers
7511 12th Street
Somers, WI 53171**

**Village Board Meeting
Agenda
Tuesday, December 13, 2022
5:30 p.m.**

Village Board Meeting:	
Item #	
1	Call to order
2	Pledge of Allegiance
3	Consent and Approval of Minutes of Regular meetings on November 22, 2022, Special Meeting November 29, 2022. Vouchers dated November 24, 2022, December 1, 2022, and December 8, 2022
4	Correspondence:
5	Citizens Comments
6	President and Trustee Comments
7	Action on request for partial payment #4 from Willkomm Excavating & Grading, Inc. in the amount of \$13,021.12 for work on 2022 Water Mains (Becknell & First Park 94)
8	Action on change order #2 from Willkomm Excavating & Grading, Inc. in the amount of \$23,433.55 for work on 2022 Water Mains (Becknell & First Park 94)
9	Discussion and Action on request for partial payment #1 from Globe Contractors, Inc. in the amount of \$433,124.00 for Flint 94 Commerce Center Offsite Public Utility Plans
10	Action on proposed Collective Bargaining Agreement between the Village of Somers and the Somers Professional Firefighters IAFF Local 4831, agreement to commence January 1, 2023 and shall be effective through December 31, 2023
11	Discussion and possible action on request from Stream Realty for the removal of the condition precedent stating that “Developer entering into a Memorandum of understanding with Kenosha County for the construction of offsite public infrastructure” from Stream Realty’s October 11th, 2022 approvals for rezoning, site plan and exterior fenestration, and developer’s

	agreement for Tax Parcel #s 82-4-222-194-0101, 82-4-222-301-0050, 82-4-222-301-0040 & 82-4-222-301-0030, located in the SE ¼ of Section 19 and the NE ¼ of Section 30, T2N, R22E, Village of Somers”
12	Action on request from Tyler and Deleen Nehls for Release of Conservation Easement on Tax Parcels # 83-4-223-064-0213 & 83-4-223-064-0214 (501-13 th Avenue)
13	Action on Ordinance No. 2022-022, An Ordinance to Create Sections 7.03(E), (F), (G), (H) and (I) of the Code of Ordinance of the Village of Somers Regarding No Parking
14	Discussion and possible action on adding a onetime stipend for new full-time employees who were hired between June 1st, 2022 and August 1st, 2022 in amount of \$1000 each.
15	Approval of Operator’s Licenses: Jennifer Vander Loop
16	Adjourn

I hereby certify that as the designee of the chief elected official of the Village of Somers, I posted this notice of the December 13, 2022 Village Board Meeting & Agenda in one ` public place & on the Village website.

Dated this 9th day of December 2022

Brandi Baker, Clerk-Treasurer

Requests from person with disabilities who need assistance to participate in this meeting should be made to the Clerk’s Office at 262-859-2822 with as much notice as possible. **Notice is hereby given that members of the Village Board may participate telephonically. Notice is hereby given that members of the Town Board may be in attendance for the sole purpose of gathering information. A quorum may be present. However, no Board action will be taken**

**Village of Somers
Proceedings from the Regular Board Meeting November 22, 2022**

President Stoner called the meeting to order at 5:30p.m.

President Stoner led the Pledge of Allegiance.

Present: President George Stoner, Trustees Gregg Sinnen, Jack Aupperle, Joe Smith, Ben Harbach, Jackie Nelson and Karl Ostby. Also present: Clerk/Treasurer Brandi Baker, Attorney Jeff Davison, and Assistant to the Administrator Ryan Vishaway.

Consent and Approval of Minutes of Regular meetings on November 9, 2022 Vouchers dated November 10, 2022 and November 17, 2022

Trustee Aupperle moved to approve the Minutes of Regular meetings on November 9, 2022 Vouchers dated November 10, 2022 and November 17, 2022

Seconded by Trustee Smith. Motion carried. 7-0 vote

Correspondence

None

Citizen Comments

None

President and Trustee Comments

Trustee Nelson thanked Administration for having the garbage information and Hall closures on the website and the outside message board.

Trustee Aupperle wished safe travels for the upcoming Holiday

Trustee Ostby would like the Auditor to attend an upcoming meeting.

Trustee Harbach expressed thanks to Trustees Nelson and Sinnen about he Making a Difference presentation.

Trustee Smith shared that HWY L might open soon and wished everyone a Happy Thanksgiving.

President Stoner wished everyone a Happy Thanksgiving.

Public Hearing on Resolution 2022-020, an Order Adding Territory to Village of Somers Utility District No. 1

President Stoner opened the Public Hearing at 5:32p.m.

No Discussion.

President Stoner closed the Public Hearing at 5:32pm

Action on Resolution 2022-020, an Order Adding Territory to Village of Somers Utility District No. 1

Trustee Nelson moved to approve Resolution 2022-020, a Petition to Add Territory to Utility District No. 1

Seconded by Trustee Aupperle. Motion carried. 7-0 vote.

Action on request for Final payment from A.W. Oakes & Son, Inc. in the amount of \$104,716.48 for the Sheridan Road Area Water Main Improvements

Trustee Sinnen moved to approve the request for Final payment from A.W. Oakes & Son, Inc. in the amount of \$104,716.48 for the Sheridan Road Area Water Main Improvements

Seconded by Trustee Aupperle. Motion carried. 7-0 vote

Approval of Operator's Licenses: Angela Quillen

Trustee Aupperle moved to approve the Operator Licenses: Angela Quillen

Seconded by Trustee Ostby. Motion carried. 7-0 vote

Adjourn

Trustee Nelson moved to adjourn at 5:34 pm

Seconded by Trustee Harbach. Motion carried. 7-0 vote.

Drafted this 23rd day of November by Brandi Baker Clerk/Treasurer

These minutes are not official until approved by the Village Board.

Village of Somers

Proceedings from the Special Village Board Meeting November 29, 2022

President Stoner called the meeting to order at 5:30 p.m.

President Stoner led the Pledge of Allegiance.

Present: President George Stoner, Trustees Gregg Sinnen, Jack Aupperle, Joe Smith, Ben Harbach, Karl Ostby, and Jackie Nelson. Also, present: Administrator Jason Peters, Assistant to Administrator Ryan Vishaway, and Attorney Jeff Davison.

Citizen Comments

None

Action on Proposal from Rudie/Frank Architecture, Inc for design of Auditorium Room Alterations, fee will not exceed \$9,240.00

Trustee Jack Aupperle motioned to approve Action on Proposal from Rudie|Frank Architecture, Inc for design of Auditorium Room Alterations, fee will not exceed \$9,240.00

Seconded by Trustee Ben Harbach. Motion carried. 7-0 vote.

Public Hearing on the 2023 Budget:

Trustee Otsby motioned to hold public hearing. Seconded by Trustee Ben Harbach. Motioned carried 7-0 vote

No Discussion

Trustee Otsby motioned to close public hearing. Seconded by Trustee Ben Harbach. Motioned carried 7-0 vote

Motion to approve Resolution 2021-021, A Resolution authorizing the adoption of the 2023 Budget, authorizing positions authorizing fees, and setting the tax levy:

Trustee Ben Harbach motioned to approve Resolution 2022-021, A Resolution Authorizing the adoption of the 2023 Budget, authorizing positions, authorizing fees, and setting a tax levy

Seconded by Trustee Otsby. Motioned carried 7-0 vote.

Adjourn

Trustee Ben Harbach moved to adjourn at 6:06 p.m.

Seconded by Jackie Nelson. Motion carried. 7-0 vote.

Drafted this 30th day of November by Brandi Baker, Clerk/Treasurer

These minutes are not official until approved by the Village Board.

11/23/2022 03:53 PM
User: jmartin
DB: Somers

CHECK REGISTER FOR VILLAGE OF SOMERS
CHECK DATE FROM 11/24/2022 - 11/24/2022

Page: 1/1

Check Date	Bank	Check	Vendor	Vendor Name	Amount
Bank POOL POOLED CASH					
11/24/2022	POOL	61038	OAK001	A.W. OAKES & SON INC	104,716.48
11/24/2022	POOL	61039	SPECTRUM	CHARTER COMMUNICATIONS	344.16
11/24/2022	POOL	61040	SPECTRUM	CHARTER COMMUNICATIONS	21.90
11/24/2022	POOL	61041	CORE	CORE & MAIN LP	1,675.00
11/24/2022	POOL	61042	EMC	EMC INSURANCE COMPANIES	24,497.60
11/24/2022	POOL	61043	KWU002	KENOSHA WATER UTILITY	42.00
11/24/2022	POOL	61044	KWU002	KENOSHA WATER UTILITY	5,780.00
11/24/2022	POOL	61045	MEN001	MENARDS - RACINE	204.12
11/24/2022	POOL	61046	RESOURCE	RESOURCE ENVIRONMENTAL SOLUTIONS	1,068.50
11/24/2022	POOL	61047	RICOHUSA	RICOH USA, INC	193.43
11/24/2022	POOL	61048	THOMPSON	THOMPSON & ASSOC WETLAND SERV	1,107.88
11/24/2022	POOL	61049	WEE001	WE ENERGIES	23.96
11/24/2022	POOL	61050	WEE001	WE ENERGIES	1,139.49
11/24/2022	POOL	61051	WEE001	WE ENERGIES	6,157.29

POOL TOTALS:

Total of 14 Checks:	146,971.81
Less 0 Void Checks:	0.00
Total of 14 Disbursements:	146,971.81

12/01/2022 11:46 AM
 User: jmartin
 DB: Somers

CHECK REGISTER FOR VILLAGE OF SOMERS
 CHECK DATE FROM 12/01/2022 - 12/01/2022

Check Date	Bank	Check	Vendor	Vendor Name	Amount
Bank POOL POOLED CASH					
12/01/2022	POOL	61053	ALA001	ALADTEC	2,230.00
12/01/2022	POOL	61054	BRUM	ANN BRUMBACK	47.15
12/01/2022	POOL	61055	BAXTER	BAXTER & WOODMAN	41,420.71
12/01/2022	POOL	61056	BAXTER	BAXTER & WOODMAN	19,430.02
12/01/2022	POOL	61057	BAKER	BRANDI BAKER	177.26
12/01/2022	POOL	61058	CGENTERPRI	C.G. ENTERPRISES	1,540.00
12/01/2022	POOL	61059	CORE	CORE & MAIN LP	495.00
12/01/2022	POOL	61060	EME001	EMERGENCY MEDICAL PRODUCTS INC	1,137.22
12/01/2022	POOL	61061	FIRESERV	FIRE SERVICE INC	1,825.69
12/01/2022	POOL	61062	FIRERESCUE	FIRE-RESCUE SUPPLY LLC	550.00
12/01/2022	POOL	61063	FUHS001	FROEDTERT SOUTH INC	404.60
12/01/2022	POOL	61064	GEAR	GEAR WASH, LLC	65.00
12/01/2022	POOL	61065	STO001	GEORGE STONER	311.99
12/01/2022	POOL	61066	HJSMET	H J SMET & SON CONSTRUCTION INC	1,550.00
12/01/2022	POOL	61067	SOR001	JOHN E SORENSEN	58.72
12/01/2022	POOL	61068	JOHNS	JOHNS DISPOSAL SERVICE INC	62,560.20
12/01/2022	POOL	61069	LIFEASSIST	LIFE-ASSIST INC	144.00
12/01/2022	POOL	61070	MEN001	MENARDS - RACINE	185.02
12/01/2022	POOL	61071	SIRENSERV	SIREN SERVICES LLC	649.96
12/01/2022	POOL	61072	STERICYCLE	STERICYCLE INC	16.01
12/01/2022	POOL	61073	TAP001	TAPCO	190.20
12/01/2022	POOL	61074	THEJOURNAL	THE JOURNAL TIMES	204.92
12/01/2022	POOL	61075	TKITZ	TIMOTHY KITZMAN	20.50
12/01/2022	POOL	61076	ULINE	ULINE	541.86
12/01/2022	POOL	61077	WAM001	WILLIAM A MORRIS	149.42

POOL TOTALS:

Total of 25 Checks:	135,905.45
Less 0 Void Checks:	0.00
Total of 25 Disbursements:	<u>135,905.45</u>

12/08/2022 01:30 PM
 User: jmartin
 DB: Somers

CHECK REGISTER FOR VILLAGE OF SOMERS
 CHECK DATE FROM 12/08/2022 - 12/08/2022

Check Date	Bank	Check	Vendor	Vendor Name	Amount
Bank POOL POOLED CASH					
12/08/2022	POOL	61078	AAC001	ASSOCIATED APPRAISAL	2,672.66
12/08/2022	POOL	61079	AT&T001	AT&T	115.44
12/08/2022	POOL	61080	AT&T001	AT&T	264.72
12/08/2022	POOL	61081	BTM001	BOUND TREE MEDICAL LLC	111.87
12/08/2022	POOL	61082	TRI-VISA	CARDMEMBER SERVICE	1,007.71
12/08/2022	POOL	61083	BORLAND	CARRIE BORLAND	400.00
12/08/2022	POOL	61084	DAV001	DAVISON LAW OFFICE, LTD	8,398.63
12/08/2022	POOL	61085	DAV001	DAVISON LAW OFFICE, LTD	4,485.88
12/08/2022	POOL	61086	FIRESEV	FIRE SERVICE INC	1,650.00
12/08/2022	POOL	61087	HWY001	HIGHWAY C SERVICE INC	226.50
12/08/2022	POOL	61088	PETERS	JASON PETERS	406.06
12/08/2022	POOL	61089	JCLICHT	JC LICHT LLC	33.99
12/08/2022	POOL	61090	JEF001	JEFFERSON FIRE & SAFETY INC	123.35
12/08/2022	POOL	61091	KEN002	KENOSHA COUNTY TREASURER	930.80
12/08/2022	POOL	61092	KWU001	KENOSHA WATER UTILITY	36,585.13
12/08/2022	POOL	61093	POIRIER	KEVIN POIRIER	1,220.00
12/08/2022	POOL	61094	LWM001	LEAGUE OF WI MUNICIPALITIES	3,821.02
12/08/2022	POOL	61095	LIC001	LINCOLN CONTRACTORS SUPPLY INC	1,579.41
12/08/2022	POOL	61096	CELEBRE	NICCOLO CELEBRE	44.00
12/08/2022	POOL	61097	OLENICZAK	OLENICZAK LAW LLC	1,221.65
12/08/2022	POOL	61098	PAT001	PATS SERVICES INC	566.13
12/08/2022	POOL	61099	PETTYCASH	PETTY CASH - CLERK TREASURER	1,000.00
12/08/2022	POOL	61100	PETTYCASH	PETTY CASH - CLERK TREASURER	119.37
12/08/2022	POOL	61101	PTS001	POMPS TIRE SERVICE INC	105.57
12/08/2022	POOL	61102	SAFEHARBOR	SAFE HARBOR HUMANE SOCIETY	845.39
12/08/2022	POOL	61103	SAMSMC	SAM'S CLUB MC/SYNCB	1,116.07
12/08/2022	POOL	61104	STAPLEAD	STAPLES	196.01
12/08/2022	POOL	61105	UOC001	UNITED OCC MED &	100.00
12/08/2022	POOL	61106	USPOST	US POSTMASTER	370.14
12/08/2022	POOL	61107	WEE001	WE ENERGIES	177.86
12/08/2022	POOL	61108	WEE002	WE ENERGIES	88.30
12/08/2022	POOL	61109	WICOURT	WI COURT FINES & SURCHARGES	3,272.53
12/08/2022	POOL	61110	WDT001	WI DEPT OF TRANSPORTATION	389.00

POOL TOTALS:

Total of 33 Checks:	73,645.19
Less 0 Void Checks:	0.00
Total of 33 Disbursements:	73,645.19

**VILLAGE OF SOMERS
VILLAGE BOARD
MEETING ITEM MEMORANDUM**

MEETING DATE: December 13th, 2022

TO: Village President Stoner and Village Trustees

PREPARED BY: Jason J. Peters, Administrator

AGENDA ITEM: #7 Action on request for partial payment #4 from Willkomm Excavating & Grading, Inc. in the amount of \$13,021.12 for work on 2022 Water Mains (Becknell & First Park 94)

#8 Action on change order #2 from Willkomm Excavating & Grading, Inc. in the amount of \$23,433.55 for work on 2022 Water Mains (Becknell & First Park 94)

BACKGROUND:

In December of 2021, the Board approved a development agreement with Becknell. The Board agreed to participate in extending water main from the corner of CTH L to the proposed project. This main will be necessary to facilitate the required fire protection flows for a project of this size.

First Park 94 Phase II Water Main project has been listed in our TID #1 CIP for some time and is listed as a 2022 project. This project will serve to “loop” the water main in the park and will serve to provide sufficient flows to our new water mains west of the subcontinental divide.

On March 22, 2022, the Board awarded the bid for 2022 Water Mains (Becknell & First Park 94) to Willkomm Excavating & Grading, Inc. in the amount of \$1,099,968.80. On September 13th, the Board approved Change Order #1 that added an additional \$13,035 to the contract. The total contract price is now \$1,113,003.80.

Partial funding for this project came in the form of \$400,000 from Becknell and the remainder will be funded by our recent General Obligation Promissory Note, 2022A from Tri-City.

Willkomm Excavating & Grading, Inc. has submitted its third request for partial payment in the amount of \$93,387.70. The Board has previously approved the following:

• 1 st request	May 24, 2022	\$409,779.36
• 2 nd request	June 28, 2022	\$591,838.24
• 3 rd request	October 25, 2022	\$93,387.70
Payments to date		\$1,095,005.30

The Village has received a fourth request for payment from Willkomm Excavating & Grading, Inc. in the amount of \$13,021.12. The Village has also received a request for Change Order #2. The net increase to the contract would be \$23,433.55. The majority of this increase was due to the need to remove a greater number of trees that were over 6 inches in diameter for the project and due to the need to use different Fire Hydrant Barrel Extensions due to supply chain issues.

PRIOR ACTION TAKEN:

Payment request #4 and Change Order #2 were reviewed at our December 6th Work Session.

SUGGESTED ACTION/ACTION REQUESTED/COMMENTS:

Engineer Biver recommends approval of Payment request #4 and Change Order #2. In the event that the Village Board agrees with the suggested action, a suggested motion to approve would be as follows:

#7

“Motion to approve request for partial payment #4 from Willkomm Excavating & Grading, Inc. in the amount of \$13,021.12 for work on 2022 Water Mains (Becknell & First Park 94)”

#8

“Motion to approve change order #2 from Willkomm Excavating & Grading, Inc. in the amount of \$23,433.55 for work on 2022 Water Mains (Becknell & First Park 94)”

ATTACHMENTS:

Engineer Biver Recommendation on Willkomm Excavating & Grading, Inc. 2022 Water Mains (Becknell & First Park 94) -Payment #4

Change Order #2

December 1, 2022

Brandi Baker, Village Clerk
Village of Somers
7511 12th Street
Somers, WI 53171

Subject: 2022 Water Mains – Payment Recommendation

Dear Village Clerk,

Enclosed is an Application for Payment from Willkomm Excavating & Grading, Inc., Contractor, for work performed on the 2022 Water Mains project. The following is our opinion of the amount due and payable to the Contractor, contingent on approval of Change Order #2:

Contract Price Including C.O. #1 & #2	\$1,136,437.35
Work Completed to Date	\$1,136,437.35
Less Amount Retained	<u>(\$28,410.93)</u>
Subtotal	\$1,108,026.42
Less Previous Payments	<u>\$1,095,005.30</u>
Total Amount Due for Partial Payment 4	\$13,021.12

A breakdown of costs attributed to TID #6 (Becknell) and TID #1 (First Park 94) will be provided at project completion.

We recommend payment to Willkomm Excavating & Grading, Inc. for \$13,021.12.

Sincerely,

BAXTER & WOODMAN, INC.
CONSULTING ENGINEERS

Brett D. Biber, P.E.

BDB/bdb

Encs.

C/encs.: Jason Peters, Administrator (email)
Doug Snyder, Village Engineer (email)
Nathan Willkomm, Willkomm, Inc. (email)

P:\SOMEV\212121-BECHNELL OFFSITE WAT\CONSTRUCTION\PAY REQUESTS\PAY REQUEST #4\PAY REQUEST #4 RECOMMENDATION.DOC

To(OWNER): Village/Town of Somers
7511 - 12th Street
Somers, WI 53171

Project: 2022 Water Main - Somers

Application No: 4
Invoice No: 22-002-4
Invoice Date: 10/18/2022
Terms: Net 30
Due Date: 11/17/2022
Period To: 10/22/2022
Project No:
Contract Date:

From: Willkomm Excavating & Grading, Inc.
17108 County Line Road
Union Grove, WI 53182
(262) 878-0877

Via(Architect/
Engineer)

For:

Original Contract sum.....	1,099,968.80
Change Orders.....	13,035.00
Contract sum.....	1,113,003.80
Completed to date.....	1,136,437.35
Retainage.....	28,410.93
Total earned less retainage.....	1,108,026.42
Previous billings.....	1,095,005.30
Current payment due.....	13,021.12
Sales tax.....	0.00
Total due.....	13,021.12

To(OWNER): Village/Town of Somers
 7511 - 12th Street
 Somers, WI 53171

Project: 2022 Water Main - Somers

Application No: 4
 Invoice No: 22-002-4
 Invoice Date: 10/18/2022
 Terms: Net 30
 Due Date: 11/17/2022
 Period To: 10/22/2022
 Project No:
 Contract Date:

From: Willkomm Excavating & Grading, Inc.
 17108 County Line Road
 Union Grove, WI 53182
 (262) 878-0877

Via(Architect/
 Engineer)

For:

No.	Description	Total Quantity	Unit	Total Cost	Total Cost	Completed Units	Current Value	Prior Value	Due This Request
1010.70	Mobilization	1	LS	2,884.00	2,884.00	1	2,884.00	2,884.00	0.00
1020.790	Construction Layout & Staking	1	LS	5,253.00	5,253.00	1	5,253.00	5,253.00	0.00
1030.457235	Drain Tile R & R	4	EA	319.00	1,276.00	0	0.00	0.00	0.00
1040.840	Tree Removal 6" ti 20" Diam	12	EA	464.00	5,568.00	36	16,704.00	16,704.00	0.00
1051.631210	Water Main (Open Cut) 12"	3,537	LF	75.00	265,275.00	3,562	267,150.00	267,150.00	0.00
1052.631611	Water Main 16" Gran BF	15	LF	417.00	6,255.00	13	5,421.00	5,421.00	0.00
1060.631320	Water Main (Direct Drill) 12"	450	LF	143.00	64,350.00	450	64,350.00	64,350.00	0.00
1070.621120	Gate Balve & Box 12"	7	EA	3,669.00	25,683.00	7	25,683.00	25,683.00	0.00
1080.61371	Gate Valve & Vault 12"	1	EA	14,662.00	14,662.00	1	14,662.00	14,662.00	0.00
1090.622160	Butterfly Valve & Box 16"	1	EA	5,318.00	5,318.00	1	5,318.00	5,318.00	0.00
1100.61821	Fire Hydrant	9	EA	6,586.00	59,274.00	9	59,274.00	59,274.00	0.00
1110.61826	Fire Hydrant Barrel Extension	9	EA	787.00	7,083.00	15.5	12,198.50	12,198.50	0.00
1120.623162	Connect to Water Main 16"	1	EA	5,083.00	5,083.00	1	5,083.00	5,083.00	0.00
1130.25896	Granular Backfill	661	LF	27.00	17,847.00	661	17,847.00	17,847.00	0.00
1141.830	Silt Fence	4,990	LF	1.85	9,231.50	5,481	10,139.85	10,139.85	0.00
1142.831	Erosion Mat	466	SY	1.55	722.30	85	131.75	131.75	0.00
1143.310	Construction Entrance	1	EA	2,259.00	2,259.00	1	2,259.00	2,259.00	0.00
1150.830	Restoration of Unpaved Areas	1	LS	13,355.00	13,355.00	1	13,355.00	0.00	13,355.00
1160.815	Traffic Control & Protection	1	LS	515.00	515.00	1	515.00	515.00	0.00
2010.70	Mobilization	1	LS	2,884.00	2,884.00	1	2,884.00	2,884.00	0.00
2020.890	Construction Layout & Staking	1	LS	5,665.00	5,665.00	1	5,665.00	5,665.00	0.00
2030.457235	Drain Tile R & R	4	EA	319.00	1,276.00	1	319.00	319.00	0.00
2040.631610	Water Main (Open Cut) 16"	3,594	LF	126.00	452,844.00	3,604	454,104.00	454,104.00	0.00
2050.622160	Butterfly Valve & Box 16"	6	EA	4,530.00	27,180.00	6	27,180.00	27,180.00	0.00
2060.61821	Fire Hydrant	6	EA	6,550.00	39,300.00	7	45,850.00	45,850.00	0.00
2070.618210	Fire Hydrant (Air Release)	4	EA	6,460.00	25,840.00	3	19,380.00	19,380.00	0.00
2080.61826	Fire Hydrant Barrel Extension	10	LF	852.00	8,520.00	15	12,780.00	12,780.00	0.00
2090.623162	Connect to Water Main 16"	2	EA	4,254.00	8,508.00	2	8,508.00	8,508.00	0.00
2100.25896	Granular Backfill	270	LF	30.00	8,100.00	276	8,280.00	8,280.00	0.00
2110.830	Silt Fence	2,500	LF	1.85	4,625.00	3,725	6,891.25	6,891.25	0.00
2120.830	Restore Of Unpaved Areas	1	LS	3,333.00	3,333.00	1	3,333.00	3,333.00	0.00
3000.01	CO 01 Excavate Topsoil & Fill	1	LS	13,035.00	13,035.00	1	13,035.00	13,035.00	0.00
					<u>1,113,003.80</u>		<u>1,136,437.35</u>	<u>1,123,082.35</u>	<u>13,355.00</u>

Becknell
 \$13,355.00

First Park
 \$0.00

WAIVER OF LIEN TO DATE

STATE OF Wisconsin)
 COUNTY OF Kenosha)

TO WHOM IT MAY CONCERN:

WHEREAS the undersigned has been employed by Village of Somer to furnish Utilities for the premises known as 2022 Water Main - Somers, of which is owned by Village of Somers

THE undersigned, for and in consideration of Thirteen Thousand Twenty One Dollars and 12/100 (\$13,021.12) dollars, and other good and valuable consideration, the receipt whereof is hereby acknowledged, hereby conditionally** waives its right to lien, under the State of Wisconsin statutes, relating to construction liens, with respect to and on said above-described premises, and the improvement thereon, and on the material, fixtures, apparatus, or machinery furnished, and on the moneys, funds, or other consideration due, or to become due, from the owner, on account of labor, services, material, fixtures, apparatus, or machinery, furnished, or which may be furnished, at any time hereafter, by the undersigned for the above-described premises. INCLUDING EXTRAS*.

DATE: 10/18/2022

COMPANY NAME: Willkomm Excavating & Grading, Inc.
 ADDRESS: 17108 County Line Road
Union Grove WI 53182

SIGNATURE AND TITLE: Nicholas D. Willkomm

* EXTRAS ARE LIMITED TO APPROVED CHANGE ORDERS TO THE CONTRACT. AMOUNT DOES NOT INCLUDE ANY CHANGE ORDER REQUEST SUBMITTED TO GENERAL CONTRACTOR, BUT NOT YET COUNTER-EXECUTED, AND ANY CHANGE ORDER STILL BEING NEGOTIATED WITH GENERAL CONTRACTOR.
 ** This waiver is conditioned upon the actual receipt of payment. If the check is returned "NSF" or payment is stopped, this lien waiver is void.

CONTRACTOR'S AFFIDAVIT

STATE OF Wisconsin)
 COUNTY OF Kenosha)

TO WHOM IT MAY CONCERN:

THE undersigned, Nicholas A Willkomm, being duly sworn, deposes and says that he is President of Willkomm Excavating & Grading, Inc., who is the contractor furnishing Site Excavation & Site Utilities on the project located at 18th St & 100th Ave and 88th Ave & 38th St, Somers WI, and owned by Village of Somers.

That the total amount of the contract, including extras*, is \$1,136,437.35, on which we have received payment of \$ 1,095,005.30 prior to this payment. That this waiver is true, correct, and genuine. That the following are the names of all parties who have furnished material or labor, or both, for said work, and all the parties having a contract or subcontract for a specific portion of said work, or for material, entering into the construction thereof, and the amount due or to become due to each, and that the items mentioned include all labor and material required to complete said work according to plans and specifications:

NAMES	WHAT FOR	CONTRACT PRICE	APPROVED CO	AMOUNT PAID	THIS PAYMENT	BALANCE DUE
Willkomm Excavating & Grading, Inc.	Utilities	\$ 345,378.90	\$ -	\$ 305,585.39	\$ 11,382.58	\$ 28,410.93
Concrete Specialties	Structure	\$ 2,274.66	\$ -	\$ 2,274.66	\$ -	\$ -
Core & Main	Pipe	\$ 708,003.18	\$ -	\$ 708,003.18	\$ -	\$ -
Reesman	Aggregate	\$ 10,288.72	\$ -	\$ 10,288.72	\$ -	\$ -
Super Aggregate	Aggregate	\$ 37,886.80	\$ -	\$ 37,886.80	\$ -	\$ -
T & T Tree	Clearing	\$ 16,200.00	\$ -	\$ 15,390.00	\$ 810.00	\$ -
Highway Landscaper	Landscaping	\$ 16,405.09	\$ -	\$ 15,576.55	\$ 828.54	\$ -
TOTAL LABOR AND MATERIAL TO COMPLETE		\$ 1,136,437.35	\$ -	\$ 1,095,005.30	\$ 13,021.12	\$ 28,410.93

That there is no other outstanding contract for said work, and there is nothing due or to become due to any person for material, labor, or other work of any kind done, or to be done, upon or in connection with said work other than above-stated.

DATE: 11/11/2022

SIGNATURE Nicholas D. Willkomm
 November, 2022

Subscribed and sworn to before me this 11th

* EXTRAS ARE LIMITED TO APPROVED CHANGE ORDERS TO THE CONTRACT. AMOUNT DOES NOT INCLUDE ANY CHANGE ORDER REQUEST SUBMITTED TO GENERAL CONTRACTOR, BUT NOT YET COUNTER-EXECUTED, AND ANY CHANGE ORDER STILL BEING NEGOTIATED WITH GENERAL CONTRACTOR.
 My Commission Expires: 5/15/2024

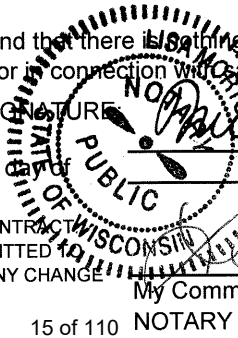

FINAL QUANTITIES
2022 WATER MAINS
VILLAGE OF SOMERS

No.	Item	Unit	BID AMOUNT		FINAL AMOUNT		Bid to Final Difference	
			Bid Qty	Unit Price	Bid Amount	Final Qty		Final Amount
SECTION A: BECKNELL OFFSITE WATER MAIN								
1	Mobilization	LS	1	\$ 2,884.00	\$ 2,884.00	1	\$ 2,884.00	\$ -
2	Construction Layout and Staking	LS	1	\$ 5,253.00	\$ 5,253.00	1	\$ 5,253.00	\$ -
3	Drain Tile Removal and Replacement	EA	4	\$ 319.00	\$ 1,276.00	0	\$ -	\$ (1,276.00)
4	Tree Removal 6" to 20" Diameter	EA	12	\$ 464.00	\$ 5,568.00	36	\$ 16,704.00	\$ 11,136.00
5a	Water Main (Open Cut) 12-Inch	LF	3,537	\$ 75.00	\$ 265,275.00	3,562	\$ 267,150.00	\$ 1,875.00
5b	Water Main (Open Cut) 16-Inch	LF	15	\$ 417.00	\$ 6,255.00	13	\$ 5,421.00	\$ (834.00)
6	Water Main (Directionally Drilled) - 12-Inch	LF	450	\$ 143.00	\$ 64,350.00	450	\$ 64,350.00	\$ -
7	Gate Valve and Box - 12-Inch	EA	7	\$ 3,669.00	\$ 25,683.00	7	\$ 25,683.00	\$ -
8	Gate Valve and Vault - 12-Inch	EA	1	\$ 14,662.00	\$ 14,662.00	1	\$ 14,662.00	\$ -
9	Butterfly Valve and Box - 16-Inch	EA	1	\$ 5,318.00	\$ 5,318.00	1	\$ 5,318.00	\$ -
10	Fire Hydrant	EA	9	\$ 6,586.00	\$ 59,274.00	9	\$ 59,274.00	\$ -
11	Fire Hydrant Barrel Extension	LF	9	\$ 787.00	\$ 7,083.00	15.5	\$ 12,198.50	\$ 5,115.50
12	Connect to Water Main (Non-Pressure) - 16-Inch	EA	1	\$ 5,083.00	\$ 5,083.00	1	\$ 5,083.00	\$ -
13	Granular Backfill	LF	661	\$ 27.00	\$ 17,847.00	661	\$ 17,847.00	\$ -
14a	Silt Fence	LF	4,990	\$ 1.85	\$ 9,231.50	5,481	\$ 10,139.85	\$ 908.35
14b	Erosion Mat	SY	466	\$ 1.55	\$ 722.30	85	\$ 131.75	\$ (590.55)
14c	Construction Entrance	EA	1	\$ 2,259.00	\$ 2,259.00	1	\$ 2,259.00	\$ -
15	Restoration of Unpaved Area	LS	1	\$ 13,355.00	\$ 13,355.00	1	\$ 13,355.00	\$ -
16	Traffic Control and Protection	LS	1	\$ 515.00	\$ 515.00	1	\$ 515.00	\$ -
	Change Order #1						\$ 13,035.00	\$ 13,035.00
SECTION A TOTAL					\$ 511,893.80	\$ 541,263.10	\$ 29,369.30	
SECTION B: FIRST PARK 94 - PHASE II WATER								
1	Mobilization	LS	1	\$ 2,884.00	\$ 2,884.00	1	\$ 2,884.00	\$ -
2	Construction Layout and Staking	LS	1	\$ 5,665.00	\$ 5,665.00	1	\$ 5,665.00	\$ -
3	Drain Tile Removal and Replacement	EA	4	\$ 319.00	\$ 1,276.00	1	\$ 319.00	\$ (957.00)
4	Water Main (Open Cut) - 16-Inch	LF	3,594	\$ 126.00	\$ 452,844.00	3,604	\$ 454,104.00	\$ 1,260.00
5	Butterfly Valve and Box - 16-Inch	EA	6	\$ 4,530.00	\$ 27,180.00	6	\$ 27,180.00	\$ -
6	Fire Hydrant	EA	6	\$ 6,550.00	\$ 39,300.00	7	\$ 45,850.00	\$ 6,550.00
7	Fire Hydrant (Air Release)	EA	4	\$ 6,460.00	\$ 25,840.00	3	\$ 19,380.00	\$ (6,460.00)
8	Fire Hydrant Barrel Extension	LF	10	\$ 852.00	\$ 8,520.00	15	\$ 12,780.00	\$ 4,260.00
9	Connect to Water Main (Non-Pressure) - 16-Inch	EA	2	\$ 4,254.00	\$ 8,508.00	2	\$ 8,508.00	\$ -
10	Granular Backfill	LF	270	\$ 30.00	\$ 8,100.00	276	\$ 8,280.00	\$ 180.00
11	Silt Fence	LF	2,500	\$ 1.85	\$ 4,625.00	3,725	\$ 6,891.25	\$ 2,266.25
12	Restoration of Unpaved Area	LS	1	\$ 3,333.00	\$ 3,333.00	1	\$ 3,333.00	\$ -
SECTION B TOTAL					\$ 588,075.00	\$ 595,174.25	\$ 7,099.25	
SECTION A & B TOTAL					Bid Total: \$ 1,099,968.80	Final Total: \$ 1,136,437.35	\$ 36,468.55	

PROJECT SUMMARY

Original contract Sum:	\$ 1,099,968.80	
Net Change by Change Order:	\$ 36,468.55	Change Orders #1 & #2
Final Contract Sum:	\$ 1,136,437.35	
Total Completed to Date:	\$ 1,136,437.35	
Retainage:	\$ -	
Total Earned Less Retainage:	\$ 1,136,437.35	
Less Previous Certificates for Payment:	\$ 1,136,437.35	
Current Payment Due:	\$ -	
Balance to Finish:	\$ -	

CHANGE ORDER SUMMARY

Change Order #1:	\$ 13,035.00
Change Order #2:	\$ 23,433.55
	\$ 36,468.55



**VILLAGE OF SOMERS
VILLAGE BOARD
MEETING ITEM MEMORANDUM**

MEETING DATE: December 13th, 2022

TO: Village President Stoner and Village Trustees

PREPARED BY: Jason J. Peters, Administrator

AGENDA ITEM: #9 Discussion and Action on request for partial payment #1 from Globe Contractors, Inc. in the amount of \$433,124.00 for Flint 94 Commerce Center Offsite Public Utility Plans

BACKGROUND:

The Village began working with Flint Development in June of 2021 regarding their desire to bring a “Class A” warehousing/industrial project to approximately 130 acres west of the I on CTH E. The project would bring three buildings totaling 1.9 million sq. ft. of warehousing/manufacturing space. These are being built as “spec” buildings. The Board conditionally approved the Flint 94’s request for comp plan amendment, rezoning, CSM, site plan and exterior fenestration at our February 8th Board Meeting. The Board approved Flint 94’s Developer’s Agreement at our June 14th meeting. As part of this agreement the Developer agreed to bring offsite public sewer and water to their project.

While these improvements are being paid for by the Develop, because these they will be public utilities they needed to be publicly bid. On October 11, 2022, the Board awarded the bid for the Offsite Public Utility Plans for Flint 94 Commence Center to Globe Contractors, Inc. in the amount of \$1,223,941.50.

PRIOR ACTION TAKEN:

This matter has not been previously reviewed by the Board.

SUGGESTED ACTION/ACTION REQUESTED/COMMENTS:

Engineer Biver recommends approval of payment request #1. In the event that the Village Board agrees with the suggested action, a suggested motion to approve would be as follows:

“Motion to approve request for partial payment #1 from Globe Contractors, Inc. in the amount of \$433,124.00 for Flint 94 Commerce Center Offsite Public Utility Plans”

ATTACHMENTS:

Engineer Biwer Recommendation on Globe Contractors, Inc. for
Flint 94 Commerce Center Offsite Public Utility Plans) -Payment #1

December 5, 2022

Brandi Baker, Clerk
Village of Somers
7511 12th Street
Somers, WI 53171

Subject: Offsite Public Utility Plans for Flint 94 Commerce Center-- Payment Recommendation

Dear Brandi,

Enclosed is an Application for Payment from Globe Contractors, Inc., Contractor, for work performed for the Offsite Public Utility Plans for Flint 94 Commerce Center Project. A partial lien waiver is also attached. The following is our opinion of the amount due and payable to the Contractor:

Contract Price	\$1,223,941.50
Work Completed to Date	\$455,920.00
Less Amount Retained	<u>(\$22,796.00)</u>
Subtotal	\$433,124.00
Less Previous Payments	<u>(\$0.00)</u>
Total Amount Due for Partial Payment 1	\$433,124.00

We recommend payment to Globe Contractors, Inc. for \$433,124.00.

Sincerely,

BAXTER & WOODMAN, INC.
CONSULTING ENGINEERS

Brett D. Biwer

Brett D. Biwer, P.E.

BDB/bdb

Encs.

C/encs.: Jason Peters, Administrator (email)
Doug Snyder, Village Engineer (email)
Brad Hucke, Globe Contractors (email)

P:\SOMEV\211728-MOSCONI - FLINT\CONSTRUCTION\PAY REQUESTS\PAY REQUEST #1\PAY REQUEST #1 RECOMMENDATION.DOC

Contractor's Application for Payment No. 1

	Application Date: 12/1/2022	Application Period: 10/31/2022-12/1/2022
To (Owner): The Village of Somers	From (Contractor): Globe Contractors, Inc.	Via (Engineer): Baxter & Woodman, Inc.
Contact: Jason Peters	Contact: Brad Hucke	Contact: Brett Biwer
Project: Offsite Public Utility Plans For Flint 94 Commerce Center	Address: N50 W23076 Betker Road Pewaukee, WI 53072	Address: 256 South Pine Street Burlington, WI 53105
Owner's Contract No.:	Contractor's Project No.: 1806-22	Engineer's Project No.: 211728.60

Change Order Summary

Approved Change Orders			
Number	Additions	Deductions (Enter as Positive Number)	
TOTALS			
NET CHANGE BY CHANGE ORDERS			

1. ORIGINAL CONTRACT PRICE	\$ 1,223,941.50
2. Net change by Change Orders	\$ -
3. CURRENT CONTRACT PRICE (Line 1 + Line 2)	\$ 1,223,941.50
4. TOTAL COMPLETED TO DATE (Column L Total on Progress Estimates)	\$ 455,920.00
5. RETAINAGE:	
a. 5% X \$455,920.00 Work Completed	\$ 22,796.00
6. RETAINAGE REDUCTION TO DATE (Enter as Positive Number) .	\$
7. AMOUNT ELIGIBLE TO DATE (Line 4 - Line 5a. + Line 6)	\$ 433,124.00
8. LESS PREVIOUS PAYMENTS (Line 7 from Prior Application)	\$
9. AMOUNT DUE THIS APPLICATION	\$ 433,124.00

Contractor's Certification

The undersigned Contractor certifies that to the best of its knowledge:

(1) all previous progress payments received from Owner on account of Work done under the Contract have been applied on account to discharge Contractor's legitimate obligations incurred in connection with Work covered by prior Applications for Payment;

(2) title to all Work, materials and equipment incorporated in said Work or otherwise listed in or covered by this Application for Payment will pass to Owner per Article 15 of the General Conditions; and

(3) all Work covered by this Application for Payment is in accordance with the Contract Documents and is not defective.

By: Brad Hucke *Brad Hucke* **Date:** 12/1/2022

Payment of: \$ 433,124.00
(Line 9 or other - attach explanation of the other amount)

Recommended by: Brett D. Biwer 12/5/22
(Engineer) (Date)

Payment of: \$ 433,124.00
(Line 9 or other - attach explanation of the other amount)

Approved by: _____
(Owner) (Date)

Progress Estimate - Unit Price Work

Contractor's Application for Payment No.

1

For (Project): Offsite Public Utility Plans For Flint 94 Commerce Center								Application Date: 12/1/2022				
Application Period: 10/31/2022-12/1/2022								Engineer's Project No.: 211728.60				
A	B	C	D	E	F	G	H	I	J	K	L	
Item No.	Description	Unit	Estimated Quantity	Bid Unit Price	Bid Item Value (\$)	Work Completed Previously		Work Completed This Period		Total Work Completed to Date		
						Estimated Quantity Installed	Value of Work Installed (\$)	Estimated Quantity Installed	Value of Work Installed (\$)	Estimated Quantity Installed	Value of Work Installed (\$)	
1	MOBILIZATION	LS	1.00	\$72,000.00	\$ 72,000.00		\$ -	1.00	\$ 72,000.00	1.00	\$ 72,000.00	
2	CONSTRUCTION LAYOUT & STAKING	LS	1.00	\$5,000.00	\$ 5,000.00		\$ -	1.00	\$ 5,000.00	1.00	\$ 5,000.00	
3	REPL OF DRAIN TILES	EA	6.00	\$1,200.00	\$ 7,200.00		\$ -		\$ -		\$ -	
4	UTILITY INVESTIGATION POTHOLE	EA	6.00	\$500.00	\$ 3,000.00		\$ -	1.00	\$ 500.00	1.00	\$ 500.00	
5	18" SAN SWR (OPEN CUT)	LF	1,896.00	\$176.00	\$ 333,696.00		\$ -	1,695.00	\$ 298,320.00	1,695.00	\$ 298,320.00	
6	18" SAN SWR W/IN 30" (MIN.) STEEL CASING PIPE	LF	426.00	\$798.63	\$ 340,216.38		\$ -		\$ -		\$ -	
7	SAN OUTSIDE DROP CONN	EA	1.00	\$25,000.00	\$ 25,000.00		\$ -	1.00	\$ 25,000.00	1.00	\$ 25,000.00	
8	48" SAN SWR MH	EA	5.00	\$16,000.00	\$ 80,000.00		\$ -	3.00	\$ 48,000.00	3.00	\$ 48,000.00	
9	TELEVISIONING OF NEW SAN SWR FOR FINAL INSPECTION	LF	2,322.00	\$3.00	\$ 6,966.00		\$ -		\$ -		\$ -	
10	12" WM (OPEN CUT)	LF	50.00	\$385.00	\$ 19,250.00		\$ -		\$ -		\$ -	
11	12" WM W/IN 24" (MIN.) STEEL CASING PIPE	LF	421.00	\$549.41	\$ 231,301.62		\$ -		\$ -		\$ -	
12	WM GRAN BF	LF	25.00	\$79.00	\$ 1,975.00		\$ -		\$ -		\$ -	
13	WM CASING VENT PIPE	EA	2.00	\$1,900.00	\$ 3,800.00		\$ -		\$ -		\$ -	
14	FIRE HYD	EA	1.00	\$9,500.00	\$ 9,500.00		\$ -		\$ -		\$ -	
15	FIRE HYD BARREL EXT	VF	2.00	\$1,300.00	\$ 2,600.00		\$ -		\$ -		\$ -	
16	12" GV & BX	EA	2.00	\$4,900.00	\$ 9,800.00		\$ -		\$ -		\$ -	
17	12" CONN TO WM (NON-PRESSURE)	EA	1.00	\$10,000.00	\$ 10,000.00		\$ -		\$ -		\$ -	
18A	SILT FENCE	LF	2,255.00	\$2.30	\$ 5,186.50		\$ -	2,000.00	\$ 4,600.00	2,000.00	\$ 4,600.00	
18B	EROSION CONTROL BLANKET	SY	6,300.00	\$1.50	\$ 9,450.00		\$ -		\$ -		\$ -	
18C	CONSTRUCTION ENTRANCE	EA	1.00	\$4,000.00	\$ 4,000.00		\$ -		\$ -		\$ -	
19	RESTORATION OF LAWNS & PARKWAYS	LS	1.00	\$39,000.00	\$ 39,000.00		\$ -		\$ -		\$ -	
20	TRAFFIC CONTROL & PROTECTION	LS	1.00	\$5,000.00	\$ 5,000.00		\$ -	0.50	\$ 2,500.00	0.50	\$ 2,500.00	
							\$ -		\$ -		\$ -	
TOTAL BID ITEMS						\$ 1,223,941.50		\$ -	-	\$ 455,920.00		\$ 455,920.00
ADDITIONAL ITEMS												
							\$ -		\$ -		\$ -	
							\$ -		\$ -		\$ -	
TOTAL ADDITIONAL ITEMS						\$ -		\$ -	\$ -		\$ -	
TOTAL ALL ITEMS						\$ 1,223,941.50		\$ -	\$ 455,920.00		\$ 455,920.00	

PARTIAL WAIVER OF LIEN

December 2nd, 2022

For value received, we hereby waive all rights and claims for lien on land and on buildings about to be erected, being erected, erected altered or repaired and to the appurtenances thereunto,

for **Village of Somers**

owner,

by **Globe Contractors, Inc.**

contractor,

for **Installation of Offsite Public Utilities (Water & Sanitary)**

same being situated in Kenosha County, State of Wisconsin, described as

Offsite Public Utility Plans For Flint 94 Commerce Center

for all labor performed and for all material furnished for the erection, construction, alteration, or repair of said building and appurtenances, except,...

Upon Receipt

Globe Contractors, Inc.



Robert D. Olson, President



**VILLAGE OF SOMERS
VILLAGE BOARD
MEETING ITEM MEMORANDUM**

MEETING DATE: December 13th, 2022

TO: Village President Stoner and Village Trustees

PREPARED BY: Jason J. Peters, Administrator

AGENDA ITEM: #10 Action on proposed Collective Bargaining Agreement between the Village of Somers and the Somers Professional Firefighters IAFF Local 4831, agreement to commence January 1, 2023 and shall be effective through December 31, 2023

BACKGROUND:

Over the past year, Administrator Peters, Attorney Davison, Chief Andersen, Trustee Sinnen, and President Stoner have worked with representatives from Somers Professional Firefighters IAFF Local 4831 on a new Collective Bargaining Agreement. The negotiations went very well, and the attached Collective Bargaining Agreement has been reviewed and approved by their membership.

Items of note for this revision of the Collective Bargaining Agreement are as follows:

- Commences on January 1, 2023 and shall be effective through December 31, 2023
- Raises- 2% in 2023, 4% in 2024 and 3% in 2025
- Language to recognize the creation and authority of the Deputy Chief
- Language allowing Captains to operate as an acting Chief if the Chief or Deputy Chief are not available.
- Language clarification on vacation selection process for probationary firefighters

PRIOR ACTION TAKEN:

This matter was reviewed and discussed at our December 6th Work Session.

SUGGESTED ACTION/ACTION REQUESTED/COMMENTS:

Administrator Peters and Chief Andersen recommend approval of the proposed Collective Bargaining Agreement. In the event that the Village Board agrees with the suggested action, a suggested motion to approve would be as follows:

“Motion to approve proposed Collective Bargaining Agreement between the Village of Somers and the Somers Professional Firefighters IAFF Local 4831, agreement to commence January 1, 2023 and shall be effective through December 31, 2023”

ATTACHMENTS:

Collective Bargaining Agreement between the Village of Somers and the Somers Professional Firefighters IAFF Local 4831,

COLLECTIVE BARGAINING AGREEMENT

BETWEEN

VILLAGE OF SOMERS

AND

**VILLAGE OF SOMERS FIREFIGHTER/EMT EMPLOYEES,
LOCAL 4831 – IAFF**

AGREEMENT

This Agreement, made and entered into at the Village of Somers, Kenosha County, Wisconsin, according to the provisions of §111.70, Wisconsin Statutes, by and between the Village of Somers as the Municipal Employer, hereinafter referred to as the “Village”, and the Village of Somers Professional Firefighters Local 4831 of the International Association of Firefighters, AFL-CIO, hereinafter referred to as the “Union”, on behalf of the employees in the bargaining unit hereinafter described; such Agreement to commence on January 1, 2023, and shall be in effect at least through December 31, 2025.

Both parties to this Agreement are desirous of continuing a harmonious employer/employee relationship and, therefore, have entered into this Agreement covering rates of pay, hours of work, conditions of employment, as well as procedures for reducing potential conflict with the expectation that these agreed-to provisions will continue such a relationship. The mutual interests of the parties hereto are recognized by this Agreement in the operation of the Fire Department that will promote efficiency and the best possible fire protection for life and property for all citizens of the Village and Town of Somers.

Article 1 -- Union Recognition.

- (A) **Recognition.** The Village hereby recognizes the Union as the exclusive bargaining representative for purposes of negotiation on all matters concerning wages, hours, and other conditions of employment for all full-time represented Village of Somers Firefighter/EMT employees, but excluding the Fire Chief and one (1) Assistant Chief, elected officials, part-time employees, paid on call employees, and all Public Works and office employees represented by Local 71, AFSCME, AFL-CIO.
- (B) **Union Activities and Discrimination.** The employer agrees that no employee will be discriminated against because of membership in or activity in connection with the Union and the employer will not discourage membership in the Union and the Union agrees that it will not conduct Union activities on the employer’s time, except as permitted herein.
- (C) **Inspection of Working Conditions and Resolving Grievances.** Any representative of the Union shall have the right to visit the Fire Department at any reasonable time for the purpose of inspecting working conditions and settling existing grievances. A Village employee on official Union business shall notify his/her immediate supervisor prior to leaving one station, and proceeding to another station, and shall notify the immediate supervisor of the other station before transacting Union business. The immediate supervisor in both instances (when he/she receives notice) shall advise the Union officer if the Union business will unreasonably interfere with Village business. Permission to conduct Union business shall not be unreasonably withheld; however, visits by Union officers shall not be used to interrupt the operation of any Village function or the various

Village departments. The Union agrees to notify the Village Clerk/Treasurer of its officers, committee members, and stewards and their areas of responsibilities prior to these individuals beginning to act in official capacities on behalf of the Union.

- (D) **Bulletin Board.** The Union will be permitted the use of a bulletin board in each firehouse for the posting of Union notices or other Union matters. Political notices of any type will be prohibited from being posted on any bulletin board provided for the posting of Union business.
- (E) **Union Meetings.** The Union is hereby granted use of a room in any fire station for its meetings. The location of such meeting shall be subject to the prior approval of the Chief. Members attending such meetings while on duty shall be subject to call during such meetings. The Union shall give the Fire Chief or the on-duty Officer in Charge reasonable prior notice of the meetings to be held.
- (F) **Negotiations.** Either party to the Agreement may select for itself such negotiator or negotiators for the purpose of carrying on conferences or negotiations under the provisions of Section 111.70, Wisconsin Statutes, as such party may determine. No consent from either party shall be required in order to name such negotiator or negotiators.

Article 2 – No Strike or Lockout.

- (A) **Defined.** During the term of this Agreement, the Union shall not cause or support, nor may any employee or employees take part in any strike, intentional slowdown, or any other interference with or stoppage of the Village's work. Any employee who violates this provision or participates in its violation shall be subject to discharge. The Village will not lock out its employees.
- (B) **Reciprocal Aid.** The Village also agrees it will not order the Fire Department into another municipality to staff that municipality's fire stations or apparatus where there is a labor dispute in progress. However, the Village will respect calls for mutual aid or reciprocal aid to emergencies, as per signed agreements.
- (C) **Union Action.** Upon notification by the Village to any Union representative that certain of its members are engaged in a violation of the provision of the preceding paragraph, the Union shall immediately and in writing, order said members to return to work or cease or desist such violate activities. The Union shall provide to the Village a copy of such order and a responsible Union representative shall publicly order the employees to return to work or cease the violate activity.

Article 3 –Condition and Duration of Agreement.

- (A) **Term.** This Agreement shall become effective as of the first day of January, 2023 and shall remain in effect for a period of three (3) years through December 31, 2025 and from year to year thereafter unless either party gives notice to the other by August 1, 2025 or August 1 of any year thereafter, to vacate or amend it.

Article 4 -- Management Rights.

- (A) **In General.** The management of the Village of Somers and the direction of the employees in the bargaining unit, including but not limited to, the right to hire, the right to assign employees to jobs and equipment in accordance with the provisions of this Agreement, the right to assign overtime work, the right to schedule work, the right to relieve employees from duty because of lack of work or for other legitimate reasons for just cause, except as otherwise provided in this Agreement, shall be vested exclusively in the Village. Each represented employee shall be required to report to and/or take direction from any management designee, who shall include: Fire Chief, Deputy Chief, any acting Chief and Village Administrator in that order of priority.
- (B) **Change in Methods and Equipment.** In the event of change of equipment or methods of operation, the Village shall have the right to reduce the working force subject to this Agreement and in the sole judgment of the Village make reductions in the work force as required. Nothing in this Agreement shall be construed to either require or to restrict the right of the Village to adopt, install, or operate new or improved equipment or methods of operation. It is further recognized by the Union that the Village of Somers Fire Department is comprised of a small group of people, both hourly and salary. As a result, both hourly union members, part-time paid on call and management may, at times, be required to work physically, hand in hand, to insure the welfare of the general public.
- (C) **Public Health and Safety.** Nothing in this Agreement shall be construed to limit the discretion of the Village with regard to matters affecting the public health, safety or general welfare.
- (D) **Work Rules.** The Union recognizes the right of the Village to establish reasonable work rules, subject to the Union’s right to grieve such rules, and to enforce applicable work related regulations promulgated by agencies of the State of Wisconsin or United States of America. These work rules shall include, but shall not be limited to, the Village of Somers Fire & Rescue Policy and Procedures Manual, the terms of which are incorporated herein by reference. Except in situations in which emergency rule changes are needed to be put in place immediately, copies of newly established work rules or amendments to existing rules will be furnished to the Union at least ten (10) days prior to the effective date of the rule.

- (E) **Subcontracting.** The Union recognizes that the Village has statutory and charter rights and obligations in contracting for matters relating to municipal operations. The right of contracting or subcontracting is vested exclusively in the Village. However, no employee shall be laid off or suffer a reduction in regular hours as a result of subcontracting.
- (F) **Community Service.** The Village participates in the community service program. The Union recognizes the Village's participation in this program and the value of such, and will cooperate with this program and its intent. However, no employee shall be laid off or suffer a reduction in regular hours as a result of the Village's participation in a community service program.
- (G) **Fire Commission.** The Village Fire Commission is recognized as having precedence over such provisions of this Agreement as are specifically provided for under authority granted the Commission by Wisconsin Statutes. Along with the hiring/promotion/disciplining of employees, the Fire Commission may appoint one (1) or more Lieutenants and Captains upon recommendation of the Fire Chief. Any Lieutenants and Captains so appointed shall receive additional compensation during their service as officers in accordance with the Schedule of Stipends for Officers, Exhibit "D" attached hereto and incorporated by reference herein.
- (H) **Overtime.** From time to time, staffing shortages may require the Village to fill in the shortage with paid-on-call (POC) or part-time members of the department. When no POC or part-time members are available to fill in the staffing shortage, the Village shall offer the fill in to the full-time employees. All overtime which is worked by a full-time employee shall be paid at one and one-half (1½) times his/her hourly rate for all such time worked. All overtime worked by a full-time employee which is mandatory overtime described in Section (2), below, shall be paid at two (2) times his/her hourly rate worked for more than twenty-four (24) hours in one (1) month or which is worked on a holiday as defined in Article 9(E)(1) below. Any portion of a full hour shall be calculated to the next quarter hour. Any full-time employee who is not released at the normal ending time of their work day and who is required to remain on-duty shall be paid at the rate of one and one-half (1½) times their hourly rate for all such time worked following their regular shift. Any portion of a full hour shall be calculated to the next quarter hour. The Village reserves the right to contact any Fire Department employee regarding the need to respond to operational problems during hours when the employee is not otherwise scheduled to work.
- (1) **Scheduled Overtime.** All scheduled overtime will be offered with a minimum of seventy-two (72) hours notice. Scheduled overtime will be distributed based upon seniority and will be offered to the most senior person first, with a maximum of twenty-four (24) hours of scheduled overtime worked per calendar month. If maximum hours are reached or the most senior person refuses scheduled overtime hours, then the hours

will be offered to the next most senior person in the bargaining unit until all hours are covered or the last person on the seniority list is reached. In the event that the least senior person refuses hours then that person would be required to work those hours pursuant to the provisions of mandatory overtime, subsection (2), below. If scheduled overtime hours are available at the beginning of a shift and are less than two (2) hours duration, those hours may be offered to an employee who is coming off shift first, regardless of seniority. No scheduled overtime will be offered to employees on a scheduled vacation day and any scheduled overtime hours which are offered with less than seventy-two (72) hours minimum notice shall be for a minimum of two (2) hours unless continuous with the end of a shift (see above).

(2) **Mandatory Overtime.**

(a) **Generally.** Management has the right to require overtime from employees, as operational requirements dictate. The employee contacted by management for mandatory overtime shall be clearly advised that the overtime is mandatory. Mandatory overtime will be distributed to the least senior member of the unit first. A maximum of twenty-four (24) hours per month of mandatory overtime will be required before maximum hours are reached and a unit member can refuse additional mandatory overtime. Upon reaching the maximum, the next least senior unit member on the seniority list shall be required to work mandatory overtime until all hours are covered or the most senior unit member is reached. In the event that all members of the bargaining unit have reached the maximum monthly overtime, additional mandatory overtime shall be required of the least senior unit member and the process will repeat. However, no employee can be forced to work more than twenty-four (24) hours of mandatory overtime in one month in the absence of a bona fide emergency. Employees required to report to work for mandatory overtime shall report within a reasonable time frame. An employee cannot be forced to report to work for mandatory overtime when that employee has taken a vacation day or a sick day or during any period between two scheduled shifts where a vacation or sick day falls in between the two scheduled shifts.

(b) **Supplemental Provisions.**

(i) In the event that management requires mandatory overtime which is in excess of twenty-four (24) hours, management may order mandatory overtime for a period not to exceed

forty-eight (48) hours in a month for any one (1) employee subject to the following:

- (a) Mandatory overtime shall not be forced on consecutive days in excess of twenty-four (24) hours unless consecutive with a scheduled or voluntary overtime shift or if a bona fide emergency is declared.
 - (b) Pursuant to federal law, management shall not exceed a mandatory overtime work period in excess of seventy-two (72) continuous hours in any combination of regular scheduled hours and mandatory hours. At the conclusion of seventy-two (72) hours of continuous work at least twenty-four (24) hours must elapse provided any further scheduled hours or mandatory overtime hours are worked by the employee. This provision also applies to a bona fide emergency declared by management.
 - (c) An employee shall not be forced to work more than twenty-four (24) hours of mandatory overtime in a running seven (7) day period including the prior or next month from the current month.
 - (d) In the event that mandatory overtime is imposed by management, no more than one (1) station change shall be required in any forty-eight (48) hour continuous period of work. Employees shall have the right to voluntarily request station changes or accept station changes more frequently than one (1) change in the forty-eight (48) hour period of continuous work. Station changes shall not occur after 18:00 hours or before 06:00 hours with the exception of a circumstance where a shift vacancy is created by a crew member leaving during a shift unexpectedly due to injury, illness or other emergency where sick time is used during the shift.
- (c) **Bona fide Emergency.** In the event that the Chief, the Chief's designee or the Village determines the need to declare a bona fide emergency for any reason, the Village shall provide within twenty-four (24) hours of declaration, in writing, the nature of the emergency, the estimated duration of the emergency not to exceed

thirty (30) days and the specific events or conditions which warrant declaration of a bona fide emergency. In the event that outside staffing is required, the Union shall be advised of the period of time when such outside staffing is deemed necessary by management and any outside staffing shall not exceed the duration of the emergency declaration as specified above.

(I) **Acting Chief.**

- (1) **Selection of Acting Chief.** If no Somers Fire Department Chief or Deputy Chief officer is available to be the on-duty Chief, the Chief may assign a represented employee as that term is defined under Article 7(A) hereafter, who is also a Captain of the Department to the position of Acting Chief. A represented employee who is designated Acting Chief shall be paid an hourly stipend of Five (\$5.00) Dollars per hour in addition to his or her normal hourly rate for the duration of time in which the employee is assigned to the position of Acting Chief. No overtime will be paid for Acting Chief duties. Any assignment as Acting Chief will be for a minimum of six (6) consecutive hours, in the same fashion that overtime shifts are assigned in accordance with Article 4(H) above. The Captain who is designated Acting Chief can already be on duty or may be an off duty Captain and will be provided a white helmet for on-call hours while designated Acting Chief.
- (2) **Selection Process.** The Chief will offer Acting Chief hours to an on-duty Captain voluntarily first in an order that is up to the Chief's discretion. If no on-duty Captains voluntarily accept the Acting Chief hours which are offered, the Chief may then offer it to off-duty Captains, in an order within the discretion of the Chief. If no off-duty Captains accept the hours, then an on-duty Captain may be forced to accept the designation of Acting Chief. If there is more than minimum staffing already on the schedule for a certain shift, the on-duty forced designation of Acting Chief can be completed before offering it to an off-duty Captain. Acting Chief duties and responsibilities shall be as delineated on the attached Exhibit "E" which is incorporated herein by reference.

Article 5 - Dues Check-Off & Fair Share Agreement.

- (A) **Dues Check-Off.** The Village shall deduct the membership dues of the Union, or an amount equivalent thereto, from the salary of any employee who signs an authorization form supplied by the Union. Such dues or equivalent amount certified by the Union shall be deducted in equal amounts from each check. Withheld amounts shall be forwarded to the Union within ten (10) days following the actual withholding together with a record of the amount and the names of those employees for whom deductions have been made. Automatic renewal of

such authorizations will be made for successive periods of one (1) year, unless written notice of the revocation is given to the Village and the Union by the employee prior to the start of any new contract year.

- (B) **Fair Share Agreement.** All employees in the bargaining unit shall be required to pay, as provided in this Article, their fair share of the costs of representation by the Union. No employee shall be required to join the Union, but membership in the Union shall be available to all employees who apply, consistent with the Union's constitution and by-laws.
- (C) **Deductions.** The Village shall deduct from the monthly earnings of all employees in the collective bargaining unit, their fair share of the cost of representation by the Union, as provided in Section 111.70(1)(f), Wis. Stats. and as certified to the Village by the Union. The Village shall pay said amount to the treasurer of the Union on or before the end of the month in which such deduction was made. The date for the commencement of these deductions shall be determined by the Union; however, all employees shall be required to pay their full fair share assessment regardless of the date on which their fair share deductions commence. The Village will provide the Union with a list of employees from whom deductions are made with each monthly remittance to the Union.
- (1) The Union shall notify the Village of the amount certified by the Union to be the fair share of the cost of representation by the Union and the date for the commencement of fair share deductions, (two (2) weeks) prior to any required fair share deduction.
- (D) **Union Certification.** The Union agrees to certify to the Village only such fair share costs as are allowed by law and further agrees to abide by the decisions of the Wisconsin Employment Relations Commission and/or courts of competent jurisdiction in this regard. The Union agrees to inform the Village of any change in the amount of such fair share costs.
- (E) **No Mandatory Membership.** The Union shall provide employees who are not members of the Union with an internal mechanism within the Union which is consistent with the requirements of state and federal law and which will allow those employees to challenge the fair share amount certified by the Union as the cost of representation and to receive, where appropriate, a rebate of any monies to which they are entitled. To the extent required by state or federal law, the Union will place in an interest-bearing escrow account any disputed fair share amounts.
- (F) **Indemnification.** The Union does hereby indemnify and shall save the Village harmless against any and all claims, demands, suits, or other forms of liability, including court costs, that shall arise out of or by reason of action taken or not taken by the Village, which Village action or non-action is in compliance with the provision of this Article, and in reliance on any lists or certificates which have

been furnished to the Village pursuant to this Article; provided that the defense of any such claims, demands, suits or other forms of liability shall be under the control of the Union and its attorneys. However, nothing in this section shall be interpreted to preclude the Village from participating in any legal proceedings challenging the application or interpretation of this Article through representatives of its own choosing and at its own expense.

Article 6 -- Equal Employment Opportunity. It is the policy of the Village to be fair and impartial in all its relations with its employees and applicants for employment without regard to his/her race, color, religion, age, gender, sexual orientation, marital status, handicap, arrest record, or national origin.

The Village will ensure that promotion, training, and transfer decisions are made in accordance with principles of equal employment opportunity and will impose only valid qualification requirements. The Village also will ensure that all other personnel actions, such as decisions concerning compensation, benefits, transfers, layoffs, returns from layoff and terminations, will be administered without regard to race, color, religion, age, gender, sexual orientation, marital status, handicap, arrest record or national origin.

Article 7 -- Types of Employees.

- (A) **Regular, Full-time.** Any represented employee who has been hired into a permanent, full-time position and who works a shift of twenty-four (24) hours per day, with forty-eight (48) hours off which constitutes approximately fifty-six (56) hours per week. This type of employee is entitled to all benefits contained in this Agreement.
- (B) **Probationary.**
- (1) **Period.** An employee shall be probationary for the first three hundred sixty-five (365) calendar days of his/her employment.
 - (2) **Completion.** Upon completion of such three hundred sixty-five (365) calendar days of employment, the employee shall be entered on the seniority list as of his/her date of hire.
 - (3) **Retention.** A probationary employee has no seniority rights and his/her retention as an employee is entirely within the discretion of the Village.
 - (4) **Extension of Probationary Period.** If the Village believes that an additional probationary period is necessary, such period may be extended by mutual agreement of the Chief and the employee.

Article 8 – Employee Responsibilities.

- (A) **Physical Examinations.** Applicants accepted for employment with the Village are required to pass a physical examination given by a physician selected by the Village at the Village's expense in accordance with Article 20 of this Agreement.
- (B) **Valid Driver's License.** Any applicant must possess, not later than the first date of work, and must maintain as a continuing condition of employment, a valid Driver's License issued by the State of Wisconsin.
- (C) **Training.** Full-time firefighters will receive one and one-half (1½) times their full-time hourly rate when participating in training, conducting training, answering fire and rescue calls or performing other services for the Village while off duty. Time is calculated on the basis of time expended. If training is scheduled during employee's regular shift, no extra compensation shall be given if he/she chooses not to take this exercise but makes it up at a later date. Every effort shall be made by the Village to schedule training so that it takes place during an employee's regularly scheduled shift to avoid overtime.
- (D) **Working Hours.** All represented employees shall begin at 0600 hours and end their shift at 0600 hours the following day.
- (E) **Fill-In Pay.**
- (1) Full-time employees who are requested or ordered by the Fire Chief to fill in for a full-time employee that is not available to work as normally scheduled, shall be paid one and one-half (1½) times his/her regular hourly rate, based on a fifty-six (56) hour work week, for such time worked.
 - (2) Employees who are not released at their regular quitting time and are required to work overtime, shall be paid at the rate of one and one-half (1½) times their regular hourly rate for such time actually worked to the next quarter (1/4) of an hour. All overtime will be paid in employees regular paycheck.
- (F) **Time Trades.** A trade of duty time may be made between full-time employees. The Village shall not incur any overtime liability under any circumstances (if applicable) as the result of such time trades. The employees recognize that use of time trades creates an obligation between the employees and it shall be the responsibility of the individuals involved in the time trade to see that they respectfully fulfill such obligations.
- (G) **EMT License.** As of August 31, 2017, every employee must possess and must maintain as a continuing condition of employment, a valid EMT I-12 license (or such other designation as may be issued by the State of Wisconsin for the highest

level of EMT licensure). Employees hired on or before August 31, 2017, will not be required to obtain paramedic status but will be required to maintain the level of licensure which has been issued to that employee as of August 31, 2017. Every full-time new hire beginning September 1, 2017, must have and maintain a State of Wisconsin issued paramedic license.

- (H) **Overtime Pay.** Overtime will be calculated and paid each pay period.
- (I) **Recording Time.** All Union employees shall be required to use the Department approved pay cycle report.
- (J) **Confidentiality of Personnel Matters.** Every employee shall maintain the confidentiality of Village personnel matters concerning both an individual's own employment and that of other Village employees. This confidentiality is to protect the interests of every Village employee.

Article 9 – Special Allowance and Village Furnished Equipment.

- (A) **Initial Issue.** Each employee, upon hiring, shall be issued the following uniform items:

3 – button down shirts with appropriate identification (patches, badges, etc.)

3 – blue Somers Fire Department t-shirts

4 – pairs of pants

1 – black belt

2 – job sweatshirts with appropriate identification (patches, badges, etc.)

- (B) **Uniform Replacement Clothing & Gear Allowance.** Full-time Fire Department personnel will receive a clothing allowance reimbursement of up to Three Hundred (\$300.00) Dollars per calendar year which will be based upon a determination by management of the need to replace individual items of clothing. Any request for reimbursement must be submitted by the first (1st) day of December of the current year. No other allowances will be made for clothing, except for uniforms or clothing damaged or contaminated in the line of duty. These will be cleaned or replaced by the Village, if an inspection by management indicates that the uniform or clothing did not need cleaning or replacement prior to the damage. All clothing worn while on duty shall conform to departmental policy concerning appropriate, authorized apparel, and only authorized apparel will be eligible for reimbursement. Departmental uniforms shall only be worn when on duty, while in transit to or from work, or at official Village sanctioned events.

- (C) **Turnout Gear.** The Village shall provide, maintain and replace all required turnout gear per NFPA standards at no cost to the employees. The Village may provide the appropriate washing and drying machines in the firehouse(s) for the routine cleaning of turnout gear.
- (D) **Additional/Upgraded Items.** Employees desiring to purchase apparel or footwear at their own cost for use in performing their duties that are not specified as part of the uniform or turnout gear supplied by the Village may do so as long as such items conform to departmental uniform guidelines.

Article 10 – Employee Rights.

- (A) **Jury Duty.** The Village recognizes that an employee may be called upon to serve as a juror from time to time. This is a responsibility that employees, as citizens, should fulfill. Employees shall be released from duty to fulfill jury duty obligations and are expected to return to work upon being released from jury duty on a daily basis. An employee fulfilling jury duty obligations shall receive his/her normal pay provided the employee turns over to the Village, his/her jury duty pay. Any employee who receives notification to report for jury duty should notify the Fire Chief as soon as possible.

- (B) **Family and Medical Leave Act Policy.**

- (1) **Introduction.** The Village’s Family and Medical Leave Act Policy is intended to conform to, and not exceed, the requirements of the federal Family and Medical Leave Act ("FMLA"). However, this Policy is intended to comply with the applicable laws and does not necessarily incorporate all provisions of such laws directly into the Village’s personnel policies. This Policy does not specifically repeat every provision of the FMLA's statutory or regulatory requirements. Posters summarizing the benefits required to be provided under federal and state law can be found with other employment related posting.

Employees may be required to provide advance notice and certain information as set forth below to be eligible for family or medical leave under this Policy. Employees may also be required to submit leave requests in writing as circumstances and applicable law permit. Employee’s use of other leaves provided by the Village for the reasons covered by law, when appropriate, will be treated as use of family and/or medical leave whenever applicable laws allow.

- (2) **Eligibility.** Employees are entitled to FMLA benefits if they:
 - (a) **Federal.** Have been employed by the Village for at least twelve (12) months (not necessarily consecutive); and have worked at

least one thousand two hundred fifty (1,250) hours during the twelve (12) months prior to the start of the FMLA leave. Time spent on paid or unpaid leave does not count in determining the one thousand two hundred fifty (1,250) hours eligibility; or

- (b) **State.** Have been employed by the Village for at least fifty-two (52) consecutive weeks and have worked at least one thousand (1,000) hours during the fifty-two (52) weeks prior to the start of the FMLA leave.

(3) **Qualifying Event and Amount of Leave.**

- (a) Eligible employees may take up to a total of twelve (12) work weeks of unpaid FMLA leave in a calendar year for the following qualifying events:
 - (i) The birth or placement of a child for adoption or, under Federal FMLA, for foster care:
 - (a) State law provides up to six (6) weeks of unpaid leave for any one child.
 - (b) Federal law requires that leave conclude within twelve (12) months after the birth.
 - (ii) To care for the employee's spouse, child or parent (includes a parent-in-law under the Wisconsin FMLA) with a serious health condition;
 - (a) State law provides eligible employees up to two (2) work weeks of FMLA family leave.
 - (iii) Family leave due to an employee's spouse, child or parent being on exigent active duty or having been notified of an impending call or order to exigent active duty as a member of the reserve components of the Armed Forces or a retired member of the regular Armed Forces or Reserve, in support of a contingency operation.
 - (iv) For the employee's own serious health condition that renders the employee unable to perform his/her job.
 - (a) State law provides eligible employees up to two (2) weeks of FMLA medical leave.

- (b) Eligible employees may take up to a total of twenty-six (26) work weeks of unpaid FMLA leave during a single twelve (12) month period (beginning on the first day the eligible employee takes FMLA leave to care for a covered service member and ends twelve (12) months after that date, regardless of the method used by the employer to determine the employee's twelve (12) work week of leave entitlement for other FMLA-qualifying reasons) to care for a spouse, child, parent, or next of kin who is a member of the Armed Forces who suffered an injury or illness while on active duty that renders the person unable to perform the duties of the member's office, grade, rank or rating.
- (c) During the single twelve (12) month period, an eligible employee shall be entitled to a combined total of twenty-six (26) work weeks of leave under federal law.
- (d) Leave qualifying for both Wisconsin and federal FMLA leave will count against the employee's entitlement under both laws and will run concurrently. When the reason(s) for qualified leave differ, the leave may not run concurrently under federal and state law, and an employee may be entitled to more than twelve (12) weeks of leave in a calendar year. This type of leave occurrence will be evaluated and reviewed with the employee at the time of the leave. Qualified leave taken under Worker's Compensation also will run concurrently with federal FMLA leave.

Under the federal FMLA, spouses employed by the Village are jointly entitled to a combined total of twelve (12) work weeks of family leave for the birth or placement of a child for adoption or foster care, and to care for a parent (but not a parent-in-law) who has a serious health condition.

- (4) **Non-Continuous or Intermittent Leave.** Employees are permitted to take leave on an intermittent (blocks of time) or reduced work schedule:
 - (a) When it is medically necessary to care for a family member with a serious health condition or because of the employee's serious health condition.
 - (b) When it is necessary to care for a family member or next of kin who suffered an injury or illness while on active duty.
 - (c) To care for a newborn, adopted or foster child. Federal FMLA leave for the birth or placement of a child for adoption or foster care may not be taken in non-continuous increments unless

approved by the Village. Under the Wisconsin FMLA, the last increment of leave for the birth or placement of a child for adoption must begin within sixteen (16) weeks of that birth or placement.

Medical or family caretaking leave should be planned so as not to unduly disrupt the Village's operations. Employees requesting non-continuous federal FMLA leave that is foreseeable based on planned medical treatment for purposes of providing care to a child, spouse or parent with a serious health condition or for the employee's own serious health condition may be required to transfer temporarily to an available alternative position for which the employee is qualified and which better accommodates recurring periods of leave than the regular employment position of the employee. An employee temporarily transferred will receive the same pay and benefits, but may be assigned different duties.

The Village allows for intermittent leave to be taken in no less than four (4) hour increments. The employee may not take, or be required to take, more leave than medically necessary to address the circumstances that caused the need for the leave.

- (5) **Payments on FMLA Leave.** In general, both Wisconsin and federal FMLA leaves are unpaid. The Village may require employees to substitute paid leave for which they are eligible (such as vacation days, personal leave, compensatory time or sick leave) for unpaid leave available accrued leave for unpaid Wisconsin FMLA.

The Village will require that any leave provided by this Collective Bargaining Agreement be substituted for federal FMLA leave.

- (6) **How to Apply for FMLA Leave.**

- (a) Employees must submit a Request for Leave form to the Village Administrator or designee at least thirty (30) days, or as soon as practicable, in advance of taking leave. If circumstances do not permit an employee to give notice in advance of taking leave, the employee must notify their supervisor and the Village Administrator or designee, and submit the Request for Leave form as soon as possible. Failure to give timely notice may result in the delay or denial of FMLA leave and may subject the employee to discipline under Village policies.
- (b) If the leave is for a family member's or the employee's serious health condition, the employee must submit a medical certification from the employee's or the family member's health

care provider within fifteen (15) days. If an employee does not provide the required certification by the designated deadline, or if the Village determines that an employee's absence is not covered as FMLA leave, the leave may not be designated as Wisconsin and/or federal FMLA leave, and the employee may be subject to discipline under Village attendance policies unless he or she uses accrued paid leave (like vacation) and/or is granted non-FMLA leave of absence.

- (c) Second or third certifications at the Village's expense and periodic re-certifications at the employee's expense may be required under certain circumstances. The Village requires periodic reports during federal FMLA leave regarding the employee's status and intent to return to work.
- (d) Forms are available from the Village Administrator.

- (7) **Health insurance Benefits and Non-Accrual of Other Benefits.** Group health insurance coverage will be maintained for employees while they are on FMLA leave, on the same terms as if the employee continued to work. The employee will be required to pay his/her regular portion of health insurance premium payments on a schedule established by the Village and consistent with this Agreement.

The Village may recover its share of health insurance premiums paid during a period of unpaid FMLA leave from an employee if the employee fails to return to work (for a minimum of thirty (30) calendar days) after the expiration of the leave. The Village may not collect the premiums if the reason the employee does not return is due to continuation, recurrence or onset of a serious health condition that would entitle the employee to leave under FMLA, or other circumstances beyond the employee's control.

Employees shall not accrue seniority or any other employment benefit during leave taken under this Policy, except that such benefits and seniority shall accrue if employee selects to use other leaves provided by the Village pursuant to Section (5) above, and if such benefits would normally accrue during that leave. The employee's position shall be held open during the leave period.

The Village may discontinue health insurance benefits after providing written notice to the employee of the cancellation of coverage for non-payment if the employee fails to make contribution towards the employee's portion of the premium payment within thirty (30) days of the due date.

- (8) **Return to Work.** Any employee returning from FMLA for their own serious health condition must provide a “Fitness for Duty” statement signed by their treating physician. Upon return from FMLA leave, an employee shall be restored to his or her original position or, if the position is not vacant, to an equivalent position with equivalent pay, benefits and other terms and conditions of employment. Any employee will not be restored to their original or equivalent position if they are unable to perform the function of their job because of a mental or physical condition, unless the condition qualifies under the ADA and a reasonable accommodation can be made.
- (9) **Definitions.**
- (a) **Child.** Biological, adopted, or foster child, stepchild, legal ward or, under the federal FMLA, the child of a person having day-to-day care of the child, or a child of a person standing “in loco parentis”, who is under eighteen (18) years of age or older and incapable of self-care because of a serious health condition.
- (b) **Covered Service Member.** A current member of the Armed Forces, including a member of the National Guard or Reserves, who is undergoing medical treatment, recuperation or therapy is otherwise in outpatient status, or is otherwise on the temporary disability retired list, for a serious injury or illness.
- (c) **Incapable of Self-Care.** The individual requires active assistance or supervision to provide daily self-care in three (3) or more of the activities of daily living (i.e. grooming, hygiene, bathing, dressing, eating) or instrumental activities of daily living (i.e. cooking, cleaning, shopping, utilizing public transportation, paying bills, maintaining a residence, using telephones and directories, and using a post office).
- (d) **Next of Kin.** The nearest blood relative other than the covered Service member’s spouse, parent, son or daughter, in the following order of priority: blood relatives who have been granted legal custody of the covered Service member by court decree or statutory provisions, brothers and sisters, grandparents, aunts and uncles, the first cousins, unless the covered service member has specifically designated in writing another blood relative as his or her nearest blood relative for purposes of military caregiver leave under the FMLA. When no such designation is made, and there are multiple family members with the same level of relationship to the covered service member, all such family members shall be considered the covered service members’ next of kin and may

take FMLA leave to provide care to the covered Service member either consecutively or simultaneously. When such designation has been made, the designated individual shall be deemed to be the covered Service member's only next of kin.

- (e) **Parent.** Biological parent, foster parent, adoptive parent, stepparent or legal guardian of an employee, or parent-in-law under the Wisconsin FMLA. Under the federal FMLA, "parent" includes an individual who provided day-to-day care to the employee when the employee was a child.

- (f) **Serious Health Condition.** An illness, injury, impairment or physical or mental condition that involves:
 - (i) Inpatient care in a hospital, hospice or residential medical care facility; or
 - (ii) Under Wisconsin FMLA, outpatient care that requires continuing treatment or supervision by a health care provider (generally defined as requiring two direct, continuous and first hand contacts by a health care provider); or
 - (iii) Under the federal FMLA:
 - (a) A period of incapacity of more than three (3) consecutive, full calendar days, and any subsequent treatment or period of incapacity relating to the same condition, that also involves:
 - (i) Treatment two (2) or more times, within thirty (30) days of the first day of incapacity, unless extenuating circumstances exist, by a health care provider, by a nurse under direct supervision of a health care provider, or by a provider of health care services (i.e. physical therapist) under orders of, or on referral by, a health care provider; or
 - (ii) Treatment by a health care provider on at least one occasion, that results in a regimen of continuing treatment under the supervision of a health care provider.
 - The first or only in person treatment visit must take place within seven (7)

days of the first day of incapacity.

- Whether additional visits or a regimen of continuing treatment is necessary within the thirty (30) day period shall be determined by the health care provider.

- (b) Any period of incapacity due to pregnancy or for prenatal care.
- (c) Chronic conditions requiring periodic treatment (defined as at least twice a year) by or under the supervision of a health care provider that continue over an extended period of time and may cause an episodic rather than a continuing period of incapacity (i.e. asthma, diabetes, epilepsy, etc.);
- (d) Permanent/long term conditions requiring supervision for which treatment may not be effective (i.e. Alzheimer's, a severe stroke, or the terminal stages of a disease);
- (e) Multiple treatments by or under the supervision of a health care provider either for restorative surgery after an accident or other injury or for a condition that would likely result in a period of incapacity of more than three (3) calendar days in the absence of medical intervention or treatment, such as cancer (chemotherapy), severe arthritis (physical therapy), or kidney disease (dialysis).

- (10) **Continuation and accrual of benefits.** Employees will remain eligible for health insurance benefits under the Village's group health plan during leave taken under this Policy, in accordance with Article 10 of this Agreement.

Employees shall not accrue seniority or any other employment benefit during leave taken under this Policy, except that such benefits and seniority shall accrue if employee selects to use other leaves provided by the Village pursuant to Section (7), above, and if such benefits would normally accrue during that leave. The employee's position shall be held open during the leave period.

- (C) **Military Reserve Leave and Pay.** Village employees who are members of a

United States or State Military Reserve Unit, will be allowed up to two (2) weeks per year for mandatory training purposes. While on such training, the employee will receive a payment from the Village such that the military reserve pay and the Village supplemental payment equals the lesser of the employee's regular gross pay (excluding overtime) or the employee's average pay per pay period based upon the preceding three (3) months, excluding from such average any weeks during which the employee was on unpaid leave. All other military leaves shall be governed by the Uniformed Services Employment and Reemployment Rights Act (USERRA).

(D) **Unemployment Compensation.** The purpose of unemployment compensation is to replace part of an employee's income if the employee is laid off or terminated through no fault of the employee. The Village pays the full cost of unemployment compensation benefits for its employees, but it does not decide who is eligible for benefit payments or how much the payment should be. This eligibility is decided by the Job Service Division of the State Department of Industry, Labor and Human Resources and the Wisconsin laws on unemployment compensation.

(E) **Holidays.**

(1) **Holidays.** There shall be a total of ten (10) recognized holidays as follows: New Years Day, Good Friday, Memorial Day, Independence Day, Labor Day, Thanksgiving Day, the day following Thanksgiving Day, Christmas Eve Day, Christmas Day and New Years Eve Day.

(2) **Work on Holidays.** The holidays listed in Section 10(E)(1) above shall be worked as normal scheduled work days. Employees shall receive two hundred-forty (240) hours of time off to be scheduled as additional vacation time in accordance with Article 10(H) of this Agreement. Said two hundred-forty (240) hours are reflected in the vacation hours listed in Article 10(H) of this Agreement. An employee must have completed his/her probationary period to be eligible for the additional vacation time.

(F) **Worker's Compensation.** All Village employees are covered by worker's compensation insurance the premiums for which are paid by the Village and which is administered under applicable Wisconsin law. Bargaining unit employees may utilize current or accumulated sick days to supplement temporary worker's compensation payments made to an injured employee. The injured employee will retain the worker's compensation benefits paid to him/her by the Village's insurer and then may request that the difference between the injured employee's gross wages (exclusive of overtime wages) paid to the employee in the preceding six (6) months less the amount of the worker's compensation benefits may be paid to the employee periodically and such payments shall reduce current or accumulated sickness/accident days credited to the injured employee pursuant to Article 10(I), hereafter.

- (G) **Funeral Leave.** The employer shall grant employees pay for lost time up to two (2) paid shifts in case of death in the immediate family, defined as mother, father, sister, brother, husband, wife, son, daughter, mother-in-law, father-in-law, stepparent or stepchild. In case of death to a sister-in-law, brother-in-law, daughter-in-law, son-in-law, grandmother, grandfather or grandchild(ren) up to one (1) paid shift will be allowed.
- (H) **Vacation.** For purposes of calculation of earned vacation time, the anniversary date of hire shall be utilized in determining the year in which an employee's vacation shall be categorized. All full-time employees shall be entitled to the following vacation:
- (1) **Earned Vacation.**
- (a) **Probationary employees.** Probationary employees shall earn twenty-four (24) hours of time off for each holiday (Section 10(E)(1)) that falls within a pay period. The employee must use these hours within the next three (3) months following when the hours were earned. The selection of time off will be directly through the Chief and will not affect the vacation selection policy (Section 10(H)(2)). No regular full-time employee shall be affected as it relates to the vacation selection policy. For the purpose of scheduling time off, the probationary employee must have the day approved by the Fire Chief. The Fire Chief reserves the right to deny any request for time off but must make sure the employee does not lose the hours off requested. When the employee reaches one (1) year of employment and is off of probation, they will be placed into the vacation policy. They will request the remaining holidays in the calendar year off, as stated in the vacation selection policy. Upon their two (2) year anniversary of employment, they will receive the additional seventy-two (72) hours of vacation time. If employee is terminated or resigns while on probation, all unused time off is forfeited without reimbursement.
- (b) **Two year employees.** Three hundred twelve (312) hours.
- (c) **Three through five year employees.** Three hundred eighty-four (384) hours.
- (d) **Six through fourteen year employees.** Four hundred eighty (480) hours.
- (e) **Fifteen through twenty-four year employees.** Five hundred fifty-two (552) hours.

- (f) **Twenty-five or more year employees.** Six hundred twenty-four (624) hours.
- (2) **Vacation scheduling.** Regular full-time employees who have completed their probationary period may submit their vacation requests to the Fire Chief and considered in accordance with the policy contained in the Somers Fire & Rescue Policy and Procedures Manual (Exhibit “C” attached hereto). No two (2) employees from the Fire Department will be allowed the same vacation period, unless this requirement is waived by the Fire Chief. Vacation should be taken in the calendar year in which it is earned; however, an employee may carry not more than seventy-two (72) vacation hours over into the first quarter of the following year in which such vacation is earned. Failure to utilize vacation by March 31 within the first quarter of the year following the year in which it is earned will result in the loss of vacation hours without compensation, unless such time is extended by the Fire Chief with the approval of the Village Administrator. Vacation shall be scheduled for a minimum of four (4) hours. Any probationary employee can begin picking their vacation days as part of the vacation selection policy at the third round in order of their seniority as it relates to Exhibit “C”. A probationary employee is allotted two hundred forty (240) of vacation time (holiday) for their first twelve (12) months of employment. These hours must be used within the first twelve (12) months of employment. A probationary employee will start their first round and pick three (3) days (seventy-two (72) hours). A probationary employee will then pick six (6) days (one hundred forty-four (144) hours) each additional round until all their hours are used. If the probationary employee is picking any of their vacation days prior to being employed for their first year, the day must be approved by the Fire Chief and will not count as a vacation day pick against any regular full-time employee. No regular full-time employee shall be affected as it relates to the vacation selection policy prior to the probationary employee completing their probationary period. All probationary employees will begin picking their hours after the second round of regular employees has been picked for their assigned shift.
- (3) **Impact of retirement or permanent disability.** Employees who retire or employees who are permanently unable to work due to a disability prior to December 31, shall be entitled to any unused vacation not taken during the calendar year of retirement or disability.
- (4) **Impact of death.** The survivors of an employee who dies prior to December 31 shall be entitled to any unused vacation pay not taken by the Employee during the calendar year of death.
- (5) In the event that a full-time employee is called in or otherwise ordered in

by management on a scheduled vacation day, the employee shall record that time as hours worked on his or time sheet and be paid his or her normal straight pay. Any hours worked during scheduled vacation time will be credited back to the employee as unused vacation time. Any hours accumulated in this manner may be scheduled as vacation hours at a later date or may be carried over to the next year according to the provisions of this Agreement. In the event that carry-over hours are utilized in the manner described immediately above, the employee will be entitled to an additional ninety (90) days from the date upon which he or she was called in on a scheduled vacation day to utilize such vacation.

(I) **Sickness and Accident Benefit.**

(1) Regular full-time employees who have completed their probationary period will be allowed up to six (6) paid shifts for sickness and/or accident per year. Unused sick days (shifts) will accrue from year to year up to a maximum of one hundred twenty (120) days (120 shifts). Upon retirement, the employee will have the option to either be paid for two-thirds (2/3) of all unused sick hours at the rate of pay upon retirement or receive a credit at that rate to be used for future group health insurance premiums post-retirement. If more than two (2) consecutive shifts are utilized as a result of sickness and/or accident, a doctor's excuse may be required to return to work. All sickness/accident days (shifts) accrued by regular full-time employees prior to the execution of this Agreement shall carry over and accrue towards the benefit limitations mentioned in this paragraph, (I).

(2) Probationary employees shall be entitled to earn sickness and accident benefits in the following manner: Probationary employees shall earn one (1) sick day (24 hour shift) after working two (2) months for the Village and shall earn an additional sick day (24 hour shift) for each two (2) months of employment with the Village during his/her probationary period. However, in the event that the employee leaves or is terminated prior to the expiration of his/her probationary period, the Village shall not be obligated to compensate for any sick days earned but unused by the probationary employee. All sickness/accident days (shifts) accrued but not used by a probationary employee shall carry over and accrue towards the benefit limitations mentioned in paragraph (I)(1) immediately above, following the successful conclusion of his or her probationary period.

(J) **Compulsory Attendance In Court.** Full-time employees from time to time will be required to appear in municipal, circuit or federal court actions. In those instances where the Village is a party to the litigation or in which it has a special

interest, any employee who is required to appear for any civil or criminal proceeding, including to give deposition testimony, shall be compensated, if on duty, at the regular rate of pay and if not on duty, at one and one-half (1½) times the employee's regular rate of pay. For purposes of this paragraph, the determination of whether the Village "has a special interest" in litigation in which it is not a party shall be made exclusively by Village management and shall include, by way of example but not by limitation, criminal actions in which an alleged wrongdoer is being prosecuted for activities which occurred within the Village or Town of Somers but in which the Village or Town is not technically a party to the action. In the event that an employee is subpoenaed to appear in a civil action in which the Village or Town is not a litigant, the employee shall be paid at his or her regular hourly rate when subpoenaed to appear to give testimony in a circuit or federal court but shall not be compensated for time associated with giving deposition testimony. In any situation where an employee receives his or her regular or overtime rate of pay for appearing to give testimony, the employee must turn over to the Village all subpoena fees or witness fees except mileage expense reimbursements.

- (K) **Village Deferred Compensation Plan.** Full-time employees shall be eligible to participate in the Village's deferred compensation plan. All contributions to such plan are made by individual employees. Participation in the plan is voluntary and the Village is under no obligation to provide any contributions to such plan.

Article 11 – Grievance Procedure.

- (A) **Definition.** A grievance is defined as a difference of opinion between an employee and the management, or between the Union and the management, concerning the meaning and application of the provisions of this Agreement.
- (B) **Grievance Matter.** Only one (1) grievance matter shall be covered in any one (1) grievance initiated. A written grievance shall contain a clear and concise statement of the grievance matter and should indicate the issue involved, the relief sought, the date the incident or alleged violation occurred, and the specific provision or provisions of the Agreement that are involved.
- (C) **Timely Initiation.** All grievances are to be presented promptly and no later than ten (10) calendar days from the date the grievant first became aware of, or should have become aware of, with reasonable diligence, the occurrence causing the grievance.
- (D) **Procedure.** The following procedure shall apply in the processing of grievances:

Step 1. If an employee believes that he/she has cause for a grievance, the employee may discuss the matter with his/her Union representative. If after such discussion, it is believed there is cause for a grievance, the matter

may be presented to the Fire Chief by both the employee and the Union representative. Such presentation will be done orally and an informal discussion will be held by the parties in an effort to resolve the grievance.

Step 2. If the grievance is not satisfactorily resolved within five calendar days from the date of the discussion in Step 1 above, the grievance shall be reduced to writing and presented to the Village Administrator. Within five (5) calendar days of the receipt of the written grievance, the Village Administrator will meet with the aggrieved employee, his/her Union representative, and the Fire Chief in an effort to resolve the grievance. The Village Administrator will issue a written answer to the grievance to the grievant and Union representative within five (5) calendar days from the date of the meeting.

Step 3. If the grievance is still not satisfactorily resolved in Step 2 above, the grievance may be appealed further to arbitration. Such intent by the grievant and Union representative(s) to arbitrate the grievance must be given by written notice to the Village Administrator (or his/her designated representative) within fifteen (15) calendar days from the date of receipt of the written answer in Step 2.

(E) **Arbitration.**

- (1) The party intending to arbitrate the grievance shall submit a Petition to Initiate Grievance Arbitration to the Wisconsin Employment Relations Commission (WERC) requesting assignment of a staff arbitrator.
- (2) The arbitration hearing shall be held at the earliest possible date that is mutually agreeable to the Arbitrator and the parties. The decision of the Arbitrator shall be limited to the grievance and shall be restricted solely to the interpretation of the provision or provisions of the Agreement pertaining to the grievance. In addition, the Arbitrator shall not modify, add to nor delete from the express terms of this Agreement. The decision of the Arbitrator shall be final and binding on the parties.
- (3) The cost of the Arbitrator and necessary arbitration proceeding expenses will be borne equally by the parties. Any other expenses such as attorney's fees, depositions, witness fees or a transcript of the proceedings shall be borne by the party incurring such expenses unless the parties agree to the sharing of specified expenses.

(F) **Time Limits.** The time limits specified in the various steps of this procedure shall not include calendar days off due to an illness or accident, holidays, or an authorized vacation. If an employee or his/her Union representative fails to process a grievance within the time limits specified, the grievance will be

considered to be withdrawn without prejudice. If the Fire Chief or the Village Administrator fails to answer a grievance with the time limits specified, the grievance will be automatically advanced to the next step of the procedure. However, the parties may extend the time limits specified in the procedure by mutual agreement.

- (G) **Work Now - Grieve Later.** In the event of a grievance, the Employee shall perform his/her assigned work task and grieve the dispute later. In the event of a safety situation, the work shall be immediately postponed until a satisfactory solution can be determined.

Article 12 -- Employee Insurance and Pension Benefits.

(A) **Health, Dental and Life Insurance.**

- (1) All full-time employees are eligible to receive individual or family coverage benefits the first month following one (1) month of employment. The current dental insurance benefits shall be continued with the entire premiums therefor paid by the Village for all full-time employees whose probationary period has been successfully completed by December 31, 2016. As to health insurance, all full-time employees who have completed their probationary period as of December 31, 2016, will be covered under the Wisconsin Public Employees Group Health Insurance Plan PO-4 option with the entire premiums therefore paid by the Village. Any full-time employee whose probationary period has been successfully completed on or after January 1, 2017 shall pay twelve (12%) percent of the then monthly premium for group health and dental insurance. The Village will also provide basic term life insurance coverage for each employee (employees only—not family members) in the face amount equal to the employee's annual wages and shall pay the premiums therefor.

The Union understands the need for the Village to investigate multiple sources as it relates to insurance. The Union supports this as it relates to not changing the members financial responsibility. Any and all financial responsibility for employee or a family member on any insurance policy will fall onto the Village and any payment, or offset, would be paid back to the employee. It is the intention of the parties that the financial responsibility for the employee would remain the same as it is in the 2022 insurance package.

- (B) **Wages.** Wages shall be paid in accordance with the attached Exhibit "A" which is incorporated herein by reference.
- (C) **Pension.** The Village shall enroll in and make pension contributions for all represented employees to the Wisconsin Retirement System (WRS). The Village

shall make contributions for the employer portion of such plan for any full-time employee. Each employee shall contribute the entire employee portion of pension contribution as determined by WRS. Any contributions made by employees shall be by payroll deduction. To the extent a change in state law is affected during the term of this Agreement and such change requires a greater or lesser contribution by either the employer or employees, both parties acknowledge that such change in state law shall supersede this paragraph and such change in the amounts of respective contributions shall be implemented immediately.

- (D) **Limited Retirement Insurance.** Retirees of the Village who were both full-time employees and members of Local 4831 as of January 1, 2011, may be entitled to payments by the Village of a portion of their premiums for continued health insurance under the then-applicable group health insurance program for the Village following their retirement and prior to their eligibility for medicare insurance, based upon the following schedule:

<u>Schedule</u>	
<u>Years of Service</u>	<u>% of GHIP</u>
25	50%
20	40%
15	33%
10	25%
5	10%

The foregoing premium payments are for the retiree only, and do not include family or spousal coverage, the cost of which shall be borne by the retiree.

Retirees shall be defined as full-time employees as of January 1, 2011, who have been eligible for health insurance coverage from the Village for a period of not less than five (5) years and who have retired from such employment. Nothing contained herein shall prohibit retirees from taking employment elsewhere. Any retiree who was not a full-time employee of the Village as of January 1, 2011, shall not be entitled to any benefit.

Article 13 – Discipline.

- (A) **Discipline.** Employees may be disciplined for just cause by the Fire Chief. The Union shall be furnished with a copy of any written notice or reprimand, suspension or discharge. The Village agrees that it will attempt at all times to use the disciplinary process as a means to correct shortcomings on the part of Village

employees in terms of their overall work performance.

- (1) The Village shall not discipline a member of Local 4831 without just cause as outlined below.
- (2) In the event of such discipline, the employee or the Union may grieve the discipline under the grievance procedure set forth above in this Article, unless the employee exercises the rights available to the employee under §62.13, Wis. Stats.

In the event the employee exercises said §62.13 rights, the Chief shall file charges with the Board only if the employee wishes to proceed under §62.13, Wis. Stats.

The employee's sole recourse from the decision of the Board of Fire Commissioners shall be in accordance with the appeal procedures provided in §62.13, Wis. Stats.

- (3) **Determination of Cause.** In any grievance of a disciplinary matter under the terms of this Article, the standard to be applied by management and the appellate bodies shall be whether or not there is cause for the discipline given all of the facts and circumstance constituting the grounds for the imposition of discipline or the determination to file charges. Cause shall be determined by applying the following criteria:
 - (a) Was the employee given advance notice of the possible or probable disciplinary consequences of the employee's conduct or was the conduct for which discipline is proposed to be imposed of such a nature that the employee knew or should have known that it was improper?
 - (b) Was the conduct upon which discipline is to be imposed reasonably related to the effective and efficient operation of the Fire Department or the Village?
 - (c) Prior to determining to impose discipline, did the Chief, or his designee, make an effort to investigate the facts relating to the conduct for which discipline is proposed?
 - (d) Was the Chief's or his designee's investigation conducted fairly and objectively?
 - (e) Did such investigation produce sufficient evidence or proof that the employee was guilty of the conduct for which discipline is proposed?

- (f) Has the Chief or his designee applied a disciplinary penalty without discrimination?
 - (g) Was the degree of discipline administered in the particular case reasonably related to the seriousness of the employee's proven offense and employee's record of service with the Fire Department?
- (4) It is intended by the parties that in the event a grievance is filed pursuant to the grievance procedure of this Agreement, the grievance procedure in the Agreement shall be the sole and exclusive remedy of the Village, the Chief, the Union, and the employee in question, and that no further discipline may be meted out to any employee based upon the subject matter of the grievance in question.

In the event that a disciplinary matter is not grieved under the terms and conditions of the grievance procedure in the Agreement, the Village and the Chief may proceed in the matter of discipline of the employee in question as permitted by law, and the employee in question shall have no recourse to the grievance procedure in the Agreement.

Discipline of an employee shall only be done according to the terms and conditions of this Agreement; however, the Chief shall have the right to suspend any employee with pay pending the outcome of any grievance filed pursuant to this Agreement or under §62.13, Wis. Stats.

- (5) This section on disciplinary proceedings shall comply with federal and state laws.
- (6) Probationary employees are subject to discharge without recourse to the Grievance and Arbitration Procedures of this Agreement.
- (7) When a grievance involves discharge, it shall be reduced to writing and referred directly to Step 2 under Article 11. Step 1 would not apply in this type of case.

Article 14 – Educational Reimbursement Program.

- (A) **Purpose.** The Tuition Aid Program encourages employees to grow professionally by increasing their knowledge and skills which, in turn, benefits the Village and may lead to improved Village services. The purpose of the Tuition Aid Program is to help employees reach their career potential by providing financial assistance on a voluntary basis for those who wish to take job-related educational courses.

While educational assistance is expected to enhance employees' performance and

professional abilities, the Village cannot guarantee that participation in formal education will entitle the employee to automatic advancement, a different job assignment, or pay increases.

- (B) **Eligibility.** To be eligible for tuition reimbursement, employees must be actively employed regular, full-time employees who have passed their probationary period as specified in Article 7 of this Agreement. Any employee desiring education assistance should consult with the Fire Chief. It is necessary to obtain advance approval of the Fire Chief before enrolling in a course of study for which an employee intends to seek reimbursement. The employee must also furnish evidence of satisfactory completion of said courses to receive reimbursement.

In order to be eligible under the Tuition Aid Program, the school offering the course(s) must be accredited by at least one of the following agencies:

- (1) North Central Association of College and Secondary Schools
- (2) Distance Education and Training Council
- (3) Wisconsin Technical College System Board

- (C) **Approved Course Work.** Tuition Aid benefits are available for courses meeting at least one of the following criteria:

- (1) Courses which are directly related to the employee's current job and would improve their skills on the job.
- (2) Courses which will prepare an employee for a promotion with the Village.
- (3) Courses taken to complete requirements for either a two-year associate degree program or a four-year bachelor's degree program or a one-year diploma program.

- (D) **Stipulations.**

- (1) All courses must be taken during off-duty hours. Employees using leave benefits expressly outlined in this Agreement are off-duty for purposes of attending courses.
- (2) There should be reasonable assurance that the employee intends to remain an active Village employee for at least three (3) years after completion of course work in order to qualify for tuition assistance at public expense.
- (3) Employees on Worker's Compensation shall remain eligible for the Tuition Aid Program.

- (4) Reimbursement will not be made to an employee who is discharged for cause or who voluntarily terminates employment with the Village before completion of a course.
- (5) Reimbursement will not be made to an employee who withdraws from a course due to personal reasons.
- (6) If an employee is laid off for reasons beyond their control subsequent to the approved enrollment, eligibility for aid will continue through satisfactory completion of the course in which the employee is currently enrolled.
- (7) The Village invests in educational assistance to employees with the expectation that the investment be returned through enhanced job performance and continuous service. If an employee voluntarily separates or is discharged for cause from the Village's employment or is not expected to return from worker's compensation leave within three (3) years of the last date upon which an education assistance payment has been reimbursed by the Village to the employee, the amount of the reimbursement must be repaid by the employee to the Village. Accordingly, each employee will be required to execute a Note requiring that employee to repay up to one hundred (100%) percent of the original educational assistance reimbursement made by the Village to that employee with such Promissory Note to be executed by the recipient at the time of reimbursement. The form and substance of such Note shall be acceptable to the Village Attorney.

(E) **Reimbursement.** Tuition will be reimbursed at the following rate:

- (1) Undergraduate Degree, Associate Degree or Masters Degree Studies = 50%
- (2) Direct job related courses = 100%

Reimbursement is made after successful completion of the approved course (a grade of "C" or above for Undergraduate/Associate Degrees and direct job related courses and, a grade of "B" or above for Masters Degree). The employee must submit the final grade and proof of payment of the tuition, to the Village.

(F) **Expenses Not Covered.** Expenses for books, supplies, lab fees and travel are not reimbursable. If the employee's tuition is covered by any grant or scholarship, the total reimbursement and the grant/scholarship together shall not exceed 100% of the total tuition amount.

(G) **GTC Paramedic Bridge Class.** In addition to the provisions contained in Articles 14(A) through (F), any current Union member who seeks to enroll and

participate in the paramedic bridge class offered by GTC may do so and Somers will be responsible for all costs and fees related directly to the class including supplies/books which are required by GTC. The Chief of the Department shall be required to approve any such enrollment so as to assure that there will be sufficient coverage for duty time within the Department. To the extent that there is a conflict between class time at the GTC paramedic bridge class and regularly scheduled duty time for an employee or employees enrolled in such class, the Fire Chief shall attempt to find coverage first by enlisting paid on call staff, all part-time staff and lastly, overtime for full-time employees. No full-time employee shall be forced to cover a shift which is left open due to another full-time employee being enrolled in the GTC paramedic bridge class. In the event that the Fire Chief is unable to cover a regularly scheduled shift where an employee is scheduled to be at the GTC paramedic bridge class, that employee must remain on shift and will be responsible to attempt to make up class time at GTC. To the extent that multiple employees from the same shift are in the GTC paramedic bridge class at the same time, it is the responsibility for all so enrolled employees to agree among themselves who will remain on shift and who will go to class. Somers will not be responsible for determining which employee must remain on shift and which employee will go to class (in the event that two employees from the same shift are scheduled to be in class at the same time) and it will be up to the employees to equalize on and off duty time where classes conflict with duty schedules. No overtime will be paid to any employee enrolled in the GTC paramedic bridge class for going to class or for clinical time during hours that are off duty.

Article 15 – Seniority.

- (A) **Definition.** The seniority of a regular employee is determined by the length of his/her service, computed in years, months and days from the first day of his/her last continuous employment. In the event of multiple employees being hired on the same date, the last three (3) numbers of the social security number of each employee shall determine seniority, with the lowest number having the most seniority.
- (B) **Recognition of Principle.** The Village recognizes the principle of seniority and the Union recognizes the need for maintaining an efficient work force. In all matters involving increase or decrease of forces, layoffs, or promotions, the length of continuous uninterrupted employment with the Village shall be given primary consideration. Skill, ability and efficiency shall be taken into consideration only where they substantially outweigh considerations of length of service, or where the most senior employee is unable to do the work.
- (C) **Uninterrupted Employment.** Uninterrupted employment shall include:
- (1) Periods of absence with leave under the FMLA provisions of this

Agreement.

- (2) Periods of absence due to illness or injury under the FMLA provisions of this Agreement.
 - (3) Periods of absence due to compensable illness or injury under the worker's compensation provisions of this Agreement.
 - (4) Periods of unpaid leave outside the scope of subsections (1), (2) or (3) immediately above, approved in advance by the Village Board.
 - (5) Periods of lay off due to lack of work per subsection (D) below.
- (D) **Layoffs by Seniority.** Layoffs of regular employees shall be subject to §62.13.Wis. Stats., and regular employee(s) laid off shall receive seven (7) calendar days' advance notice of the layoff. The bargaining committee of the Union shall be notified of all layoffs and all employee(s) being recalled at the time such notice is given. If a more senior employee desires to accept a layoff, he/she may choose to take such layoff. Employees shall be on layoff status for up to twenty-four (24) months and shall be entitled to recall during such period.
- (E) **Loss of Seniority.** An employee's seniority and the employment relationship shall be broken and terminated:
- (1) If he/she resigns.
 - (2) If he/she has been discharged for just cause and such discharge has not been challenged in accordance with the grievance procedure.
 - (3) If he/she fails to report to work within two (2) weeks after being recalled from layoff by the Village.
 - (4) Exhaustion of benefits under the provisions of this Agreement pertaining to FMLA.
 - (5) If the Employee fails to report to work following the expiration of an approved leave of absence.
- (F) **Seniority List.** The employer shall furnish an up-to-date master seniority list by May 1st of each year to the Union.

Article 16 – “For Cause” Drug Testing.

- (A) **Policy for Drug Testing Based Upon Reasonable Cause.** It is the policy of the Village of Somers that employees must be free of the influence of alcohol and

drugs to insure the health and safety of themselves, the public and their co-workers. Therefore, whenever any management employee has reasonable cause to believe that an employee is under the influence of alcohol or drugs, the employee may be required to submit to a drug or alcohol screening test. It is also the Village's policy that absent discipline for the misconduct, the initial response to positive test results will be to offer counseling through the Employee Assistance Program. In addition, employees who have a drug or alcohol problem will be encouraged to voluntarily seek help through the Employee Assistance Program. The Village of Somers is committed to preserving personal dignity and rights and affirms that this drug testing policy is designed to protect the rights of all employees and the public and is part of a system to provide a safe and productive place to work.

(B) **Policy Statement.**

- (1) The Village recognizes drug and alcohol dependency as an illness and a major health problem. The Village also recognizes drug and alcohol abuse as a potential health, safety and security problem. Employees needing help in dealing with such problems are encouraged to use the Employee Assistance Program and health insurance plans, as appropriate. Conscientious efforts to seek such help will not jeopardize an employee's job and it will not be noted in any personnel record.
- (2) Employees are expected and required to report to work on time and in appropriate mental and physical condition for work. It is the Village's intent and obligation to provide a drug free, helpful, safe and secure work environment.
- (3) The unlawful manufacture, distribution, dispensation, possession or use of a controlled substance on Village premises, or while conducting Village business off Village premises, is absolutely prohibited. Violations of this policy will result in disciplinary action up to and including termination and may have legal consequences.

- (C) **Reasonable Cause Testing.** An employee is subject to testing when there is reasonable cause to believe the worker is under the influence of alcohol or a drug or whose performance gives rise to a reasonable suspicion that alcohol or drugs are the cause of the poor performance. The decision to require a drug or alcohol test must be based upon a reasonable and definable belief of probable drug or alcohol use that is supported by evidence of specific contemporaneous physical, behavioral or performance indicators. All supervisory employees will be provided with training in detecting possible symptoms of drug use. Other employees may observe that a co-worker is under the influence of drugs or alcohol. Employees have an obligation to report such observations to their supervisor, especially when the safety of the employee, co-workers or the public is involved. The supervisor

must then establish reasonable cause through observation or conversation with the employee suspected of being under the influence.

On a first offense which does not involve the injury to a third party or to the employee, employees will not be terminated for voluntarily seeking assistance for a substance abuse problem. However, performance, attendance or behavioral problems may result in termination of employment.

If a supervisor has reasonable suspicion to believe that an employee is under the influence of drugs or alcohol or that drug or alcohol use is responsible for performance problems, the supervisor, with the Fire Chief and/or the Village Administrator may order the employee to submit to a drug and/or alcohol screening test.

Upon being informed that a drug or alcohol test is being ordered, the employee may admit to being under the influence, or to having a problem, and seek referral to the Employee Assistance Program. If the employee refuses to accompany the supervisor, or other management person, to the testing site or if the employee refuses to sign the consent form, such refusal will be considered insubordination and will constitute an irrebutable presumption of just cause for termination of employment. A supervisor or management person will transport the employee to the test site, will provide identification of the employee and will wait for the process to be completed. The employee will be allowed to have a Union representative accompany him/her and the supervisor to the test site. After the test is completed, the employee will be provided transportation home and will be relieved of duty with pay, pending the results of the test. If it is suspected that the employee is under the influence of alcohol or drug, the employee will be taken to the appropriate testing site for a Blood Alcohol Content test or drug screening. Blood alcohol content in excess of .00 % shall be a violation of this provision.

An employee, while on duty, involved in any accident or incident that results in personal injury to the employee, a co-worker or a citizen, shall be required by the Chief or his designee, shall submit to a drug screening or Blood Alcohol Content test as soon as possible after the accident or incident. The Village will pay for the cost of the test(s). Refusal to submit to testing under such circumstances shall constitute an irrebutable presumption of just cause for insubordination resulting in termination of employment.

Employees arrested for off-the-job drug involvement may be considered to be in violation of the Village's substance abuse policy and shall constitute reasonable suspicion for testing. Where available evidence warrants, the Village will bring matters of illegal drug or alcohol use to the attention of the appropriate law enforcement authorities.

Employees on physician-prescribed medication must notify their supervisor if

there is a possibility that such medication could affect job performance or safety.

- (D) **Drug Test Procedure.** The collection, transportation and testing of the specimen will be done in compliance with the protocols established by the U.S. Department of Health and Human Services under the “mandatory guidelines for federal workplace drug testing programs”. These guidelines require the use of confirmatory tests, the establishment of strict chains of custody and specimen control, the utilization of testing procedures and testing laboratories that have clear records of reliability and validity, and providing the right to review all aspects of the drug testing procedures. All testing shall be administered by United Occupational Medicine, 9555 76th Street, Pleasant Prairie, WI 53158.

The drug test will include, but may not be limited to the following:

- Amphetamines Screen
- Barbiturates Screen
- Cocaine Metabolite Screen
- Methadone Screen
- Opiates Screen
- Benzodiazepines Screen
- Methaqualone Screen
- Phencyclidine Screen
- Propoxyphene Screen
- THC 100 NG Screen
- Nubain
- Rohypnol

Any detectable amounts below NIDA established threshold amounts would be reported as negative.

If the test result is negative, the employee will be immediately notified and returned to work on the next scheduled shift. Positive test results will be referred to the Medical Review Officer (MRO). The MRO will be a licensed physician with knowledge of substance abuse disorders. The Medical Review Officer will review, interpret and verify confirmed positive tests results obtained as part of this policy. Before making a final decision to verify a positive test, the MRO must give the test employee an opportunity to discuss the test result. The MRO must contact the worker confidentially to determine whether the employee wishes to discuss the test result. A staff person under the MRO’s supervision may make the initial contact, while a medically licensed or certified staff person may gather information from the employee.

When a result is reported as positive, the employee may request a retest of the specimen at his/her expense. The testing laboratory selected by the employee must be federally certified and the specimen will be sent directly from the original

testing lab using appropriate chain of custody protocol. In the event the retest is negative, the Village, at the Village's expense, may seek a second retest from a testing laboratory selected by the Village and which has no association with either the first or second testing laboratory.

At any time, the Union, upon request, will have the right to inspect and observe any aspect of the drug testing program with the exception of individual test results. The Union may inspect individual test results if the release of this information is authorized by the employee involved.

(E) **Disciplinary Actions Based Upon Reasonable Cause.**

(1) **First Incident.**

- (a) The employee admits to being under the influence of alcohol or drugs but does not seek referral to the Employee Assistance Program.

Action: Employee will be terminated

- (b) The employee admits to being under the influence of or tests positive for alcohol or drugs and seeks referral to the Employee Assistance Program. In the event the employee admits to being under the influence of drugs or alcohol, testing shall be mandatory.

Action: The employee will be suspended for the remainder of the shift without pay and will be referred to the Employee Assistance Program. A written disciplinary notice will be placed in the employee's file but will be removed after one (1) year following the successful completion of the treatment program. The employee will be allowed to use any accumulated sick leave for required inpatient or outpatient treatment that is scheduled during normal work hours. The employee may be issued discipline for other misconduct up to and including termination, particularly if injury to the employee or a third party resulted in connection with the incident. Failure to participate in the Employee Assistance Program shall result in immediate discharge and no recourse to the grievance procedures contained herein.

(2) **Second Incident Within Three Years of the First Incident.**

Action: Discharge.

All information related to the drug testing and results, whether positive or negative, will be kept in a file separate from the employee's personnel file so that

any future personnel actions are not influenced by such information. Written disciplinary actions, however, will be part of the personnel file.

- (F) **Hold Harmless.** This drug testing program is solely initiated at the behest of the Village. The Village shall be solely liable for any legal obligations and costs arising out of the provisions and/or application of the Collective Bargaining Agreement relating to drug testing. The Union shall be held harmless for the violation of any worker rights arising from the administration of the drug testing program provided such Union action is consistent with this Article.

Article 17 – Random Drug Testing Policy and Procedure.

(A) **Employees Subject to Testing.**

- (1) The parties agree to the establishment of a random testing program that shall include all current union and probationary employees covered by this Agreement which shall be administered by United Occupational Medicine, 9555 76th Street, Pleasant Prairie, WI 53158.
- (2) A “pool” group refers to a group of employees subject to a specific set of random selection parameters, such as the rate and periodicity of selections. It is the phrase used to describe the total sample group of employees from which the randomly selected employees will come. The Village will develop its own pool group. Any employee who has not performed bargaining unit work during the program period shall not be included in the pool group. In its discretion, the Village may add additional employees, including from other collective bargaining units, managers and any other non-Union member to its pool group.

(B) **Random Rate.**

- (1) The random “rate” is the number of selections per program period as a percentage of the pool size.
- (2) The program administrator chosen by the Village shall decide on its respective random rate for its company within the designated program period. Because the process is random, it is possible that a significant number of the selections will repeat, meaning that some employees may get picked more than once.
- (3) The random rate may be adjusted at the beginning of any program period at the discretion of the Village’s program administrator.

(C) **Program Period.**

- (1) The “program period” refers to the period of time during which the random rate will be calculated. By the time the period closes, the number of completed tests must be equal the random rate.

(D) **Selection Period.**

- (1) The selection period is an interval within the program period for which a given number of random selections are performed. The frequency of selection shall be once during each calendar month, although the actual specimen collection may occur on any working day within that calendar month.
- (2) The Village shall submit a current employee list for each selection period to a third party administrator that will computer-generate a list of randomly-selected employees.
- (3) To ensure the deterrent effect of random testing, testing shall be spread out through the selection period and include a representative sample of all work days, including weekends and holidays when feasible. In no event shall an employee be required to submit to testing when the employee is not physically present on the job and engaged in bargaining unit work for the Village.

(E) **Testing Procedures.**

- (1) The cost of all tests, specimen collection and random selection shall be borne by the Village. Each randomly-selected employee shall be responsible for getting to and from the collection site in a timely manner. Failure of the employee to get to the testing site in a timely manner shall be deemed a refusal to be tested unless the employee can demonstrate by clear and convincing evidence that the failure to so appear was outside the employee’s control. The Village shall be responsible for transporting any employee who does not have an individual means of transportation.
- (2) Employees are required to cooperate in all specimen collection and/or testing procedures. This shall include providing a sample either on the job or collection location and having in their possession valid picture identification and any testing paperwork given to the employee by the Village.

(F) **Testing.**

- (1) The laboratory performing all tests will be certified for Federal Workplace Drug Testing Programs by the Department of Health Services - Substance Abuse and Mental Health Service Administration (SAMHSA).

- (2) Specimen samples shall be collected at the third party administrator collection location or at the job by a third party administrator who has been properly trained to collect specimen samples to meet guidelines established by the Department of Transportation.
- (3) A split sample shall be secured from each employee tested. When a urine sample is taken, the sample will be collected in a single container and then split into two containers by the collector. When an oral swab is taken, the collector shall swipe into two separate swabs and keep each swab separate.
- (4) All initial tests will be tested by the accepted industry standard screening methodology appropriate for the type of specimen. All initial positive tests shall be confirmed by gas chromatography/mass spectrometry (GC/MS) or the appropriate industry standard confirmatory methodology appropriate for the type of specimen.
- (5) Urine and/or oral fluids may be tested.
- (6) Testing for alcohol shall be at the option of the Village. Testing for alcohol shall follow 49 CFR Part 40 Subparts J and K Procedures for Transportation Workplace Drug and Alcohol Testing Programs for the Department of Transportation, as that provision may from time to time be amended.
- (7) All illegal drugs, controlled substances, look-alike drugs, and designer drugs, may be tested for.
- (8) Use of prescription drugs outside the parameters of the prescription and physician's advice may be tested for.
- (9) The United States Department of Transportation levels for "positive" or "negative" drug test results shall be the standard when applicable. Alcohol test results of .02 and higher shall be treated the same as a positive test result.
- (10) All confirmed positive test results shall be reviewed, verified and reported to the Village by the Medical Review Officer (MRO). The MRO shall not review positive alcohol tests reported from the breathalyzer.

(G) **Test Results.**

- (1) Test results that are verified by the MRO as positive or positive dilute shall be handled in accordance with the Agreement, including termination of employment.

- (2) Test results that are verified by the MRO as adulterated or substituted as determined by the laboratory and verified by the MRO shall be treated as a positive test result.
- (3) Test results that are verified by the MRO as negative dilute shall allow for a new specimen collection and test at the Village's discretion. The second test result shall be considered the test of record and the first result disregarded.
- (4) Test results that indicate misuse of prescription drugs which have not been prescribed to the tested employee shall be treated as a positive test result.
- (5) A refusal to provide a sample shall be treated as a positive test result.
- (6) Specimen samples that cannot be collected, or collected properly due to an uncooperative employee shall be treated as a positive test result and handled in accordance with this Agreement.
- (7) In the case of a specimen sample that cannot be collected because an employee does not provide a sufficient amount of urine for the drug test (i.e. 45 ml of urine), the following procedures shall be followed:
 - (a) The collector must discard the insufficient specimen, except where the insufficient specimen was out of temperature range or showed evidence of adulteration or tampering, in which case the test is treated as a positive or positive dilute test result.
 - (b) The employee shall be given the opportunity to drink fluids but shall not be forced to drink fluids. The employee shall be informed that he or she has up to three (3) hours to produce an adequate urine specimen, and when that three (3) hour period begins and ends.
 - (c) If the employee refuses to attempt to provide a new urine specimen or leaves the collection site before the collection process is complete, it is treated as a refusal to test.
 - (d) If the employee is unable to provide an adequate urine specimen after the conclusion of the three (3) hour period, the collector must immediately inform the employer and follow 49 CFR Part 40.193 Procedures for Transportation Workplace Drug and Alcohol Testing Programs from the Department of Transportation, as that provision may be from time to time amended. The Village, at its option, can require testing by an alternate method, including blood or oral fluids.

- (8) Test results that indicate a fatal flaw, invalid sample, cancelled test, damage in shipment, defect in collection procedures, laboratory errors shall result in a new specimen collection and test at the Village's option.

(H) **Disciplinary Actions Based Upon Random Testing.**

(1) **First Incident.**

- (a) The employee admits to being under the influence of alcohol or drugs but does not seek referral to the Employee Assistance Program.

Action: Employee will be terminated

- (b) The employee admits to being under the influence of or tests positive for alcohol or drugs and seeks referral to the Employee Assistance Program. In the event the employee admits to being under the influence of drugs or alcohol, testing shall be mandatory.

Action: The employee will be suspended for the remainder of the shift without pay and will be referred to the Employee Assistance Program. A written disciplinary notice will be placed in the employee's file but will be removed upon successful completion of the treatment program. The employee will be allowed to use any accumulated sick leave for required inpatient or outpatient treatment that is scheduled during normal work hours. The employee may be issued discipline for other misconduct up to and including termination, particularly if injury to the employee or a third party resulted in connection with the incident.

(2) **Second Incident Within Three Years of the First Incident.**

Action: Discharge.

All information related to the drug testing and results, whether positive or negative, will be kept in a file separate from the employee's personnel file so that any future personnel actions are not influenced by such information. Written disciplinary actions, however, will be part of the personnel file.

(I) **Employee Assistance.**

- (1) Employees are encouraged to seek help for a drug or alcohol problem before it deteriorates into a disciplinary matter. If, prior to submitting to a random test under this Agreement, an employee voluntarily notifies the Village Administrator or Fire Chief that he or she may have a substance

abuse problem, the Village will assist the employee to enroll in the Employee Assistance Program (EAP) for that treatment, and will also counsel the employee regarding medical benefits available under the Village's health and welfare/insurance program.

- (2) If treatment necessitates time away from work, the Village shall provide for the employee an unpaid leave of absence for purposes of participation in an agreed upon treatment program. An employee who successfully completes a rehabilitation program shall be reinstated to his/her former employment status, if work for which he/she is qualified exists. In no event shall a current employee be discharged or laid off to create an employment position for an employee returning from the EAP.
 - (3) Employees returning to work after successfully completing the rehabilitation program will be subject to drug tests without prior notice for a period of one (1) year. A positive test will then result in disciplinary action as previously outlined in this policy and program.
- (J) **Hold Harmless.** This drug testing program is solely initiated at the behest of the Village. The Village shall be solely liable for any legal obligations and costs arising out of the provisions and/or application of the Collective Bargaining Agreement relating to drug testing. The Union shall be held harmless for the violation of any worker rights arising from the administration of the drug testing program provided such Union action is consistent with this Article.

Article 18 – Consolidating, Merging or Combining Services.

The Village may pursue consolidation, merger or combining of its Fire Department with that of another municipality provided that the new fire protection/E.M.S. provider employs all members represented by Local 4831. The Village shall, in the event of such a consolidation, merger or combining of such services, guarantee the wages in effect at that time for a period of eighteen (18) months, or until the members are covered by a Collective Bargaining Agreement with the new fire protection/E.M.S. provider, whichever occurs first.

Article 19 – Residency.

Employees shall be required to reside in the State of Wisconsin within fifteen (15) linear miles of the corporate limits of the Village or Town of Somers.

Article 20 – Medical Examinations.

The Union agrees that all members shall submit to periodic medical examinations in accordance with this Article.

- (A) The Village shall bear the cost of medical examinations unless the 1st and 2nd

opinion is “unfit for duty”. If the 1st opinion is “unfit for duty” the employee shall bear the entire cost of the 2nd opinion unless the 2nd opinion is “fit for duty”, in which case the cost shall be shared equally by the Village and the employee. All members shall be evaluated medically by the Village’s physician (or in the case of a 2nd or 3rd opinion, by the physician rendering such 2nd or 3rd opinion) as meeting the medical requirements of NFPA 1582, Standard on Medical Requirements for Fire Fighters.

- (B) The Village shall schedule the 1st medical examination while employees are on duty. Off duty employees may agree, but shall not be required, to report to duty for medical examination for the 1st examination.
- (C) All medical examinations hereunder shall occur periodically as scheduled hereafter and shall include the following tests:
 - (1) Pre-employment Examination. This shall include a medical and occupational history including a history of any significant prior exposures. In addition, height, weight, and vital signs including blood pressure will be taken. This would also include a hearing test, pulmonary function test, and vision test. Lab testing will consist of CBC and chemistry panel and PSA screening for all male employees over 40 years of age. Additional tests will be required to work into the periodic examinations depending upon age.
 - (2) Periodic Examinations. This shall occur within thirty (30) days of an employee’s anniversary date and shall be every three (3) years between 30 and 39 years of age, and every two (2) years after 40 years of age. In addition to the components of the pre-employment examination, periodic medical examinations shall include:
 - (a) 30 years of age – medical and occupational history and physical exam, vision test, pulmonary function test, audiogram, CBC, and chemistry panel.
 - (b) 34 years of age – medical and occupational history and physical exam, vision test, and audiogram.
 - (c) 37 years of age – medical and occupational history and physical exam, vision test, and audiogram.
 - (d) 40 years of age – medical and occupational history and physical exam, vision test, pulmonary function test, audiogram, CBC, and chemistry panel.
 - (e) 42 years of age – medical and occupational history and physical

exam, vision test, and audiogram.

- (f) 45 years of age – medical and occupational history and physical exam, vision test, audiogram gram, and treadmill/stress test.
- (g) 48 years of age – medical and occupational history and physical exam, vision test, and audiogram.
- (h) 50 years of age – medical and occupational history and physical exam, vision test, pulmonary function test, audiogram, CBC, chemistry panel, and treadmill/stress test.
- (i) 52 years of age – medical and occupational history and physical exam, vision test, and audiogram.
- (j) 55 years of age – medical and occupational history and physical exam, vision test, audiogram gram, and treadmill/stress test.
- (k) 57 years of age – medical and occupational history and physical exam, vision test, and audiogram.
- (l) 60 years of age – medical and occupational history and physical exam, vision test, pulmonary function test, audiogram, CBC, chemistry panel, and treadmill/stress test.
- (m) The same pattern would be continued until retirement from the department.

These tests may be adjusted as is indicated by prevailing medical standards such as NFPA, OSHA, CDC and the IAFF/IAFC Joint Wellness Fitness Initiative and in consult with the Occupational Medicine Physician and/or other physicians involved in the determination of exam content.

- (D) Management shall be obligated to provide the examining physician with a copy of the employee’s job description for use in determining a member’s fitness for duty. The job description for the employee may be amended from time to time.
- (E) In the event the examining physician determines an employee is not fit for duty, the employee shall be placed on approved sick leave (i.e. sick days) until the employee is rehabilitated and determined to be “fit for duty”. In the event the employee has no available sick days, the employee may substitute other paid leave (i.e. vacation) for which the employee is eligible. Thereafter, the employee shall be placed on FMLA leave until the employee has exhausted the 2nd opinion option provided under this contract, but in any event, for no longer than sixty (60) calendar days.

- (F) In the event an employee disagrees with the opinion of the examining physician, the employee shall be entitled to obtain, at his/her expense, a 2nd opinion from a physician selected by the employee which shall be scheduled during off-duty hours. The Village, upon being notified by the employee of the name and address of the 2nd physician, shall provide the second examining physician with the job description for the employee. The employee shall be obligated to disclose to the 2nd physician the opinion of the 1st. In the event the 2nd opinion determines the employee is fit for duty, the employee shall be immediately returned to duty upon notice for his/her fitness for duty to the fire chief and shall receive any lost sick time, benefits and/or wages unless the Village asks for a 3rd opinion.
- (G) Where the employee is determined to be unfit for duty according to the 1st medical examination but fit for duty according to the 2nd medical examination, the Village may, but need not, require the employee to submit to a 3rd medical examination by a physician selected by the Village.
- (H) If the Village requires a 3rd medical examination under paragraph (G) above, management shall provide the 3rd examining physician with the job description for the employee. The employee shall be obligated to disclose to the 3rd physician the opinion of the 1st and 2nd physician. In the event the 3rd opinion determines the employee is fit for duty, the employee shall be immediately returned to duty upon notice of his/her fitness for duty to the Fire Chief and shall receive any lost sick time, benefits and/or wages. Under these circumstances the cost of the 3rd opinion shall be borne by the Village. In the event the 3rd physician determines the employee is unfit for duty the 3rd physician shall render an opinion as to whether the employee can be rehabilitated and when the employee is expected to be fit for duty. The employee may then utilize any remaining benefits under sick days, vacation days or FMLA for rehabilitation. At the conclusion of such benefit periods if the employee is still not fit for duty, then the employee will be terminated.
- (I) Where the employee is determined to be unfit according to both the 1st and 2nd medical examinations, the employee may then utilize any remaining benefits under sick days, vacation days or FMLA for rehabilitation. At the conclusion of such benefit periods if the employee is still not fit for duty, then the employee will be terminated.
- (J) In the event the 3rd examining physician determines that the employee is unfit for duty, the employee shall continue to utilize any remaining benefits under sick days, vacation days or FMLA for rehabilitation. At the conclusion of such benefit periods if the employee is still not fit for duty, then the employee will be terminated.

Article 21 – Annual Physical Fitness Testing.

The Union agrees that each member assigned to emergency operations shall maintain his/her personal physical fitness at a level sufficient to pass the annual physical performance examination.

(A) **Annual Physical Performance Evaluation.**

- (1) Each member shall be evaluated and certified annually as meeting the department's minimum physical performance requirements.
- (2) The evaluation shall consist of passing the department's entry-level physical ability test, Exhibit "B" attached hereto, and shall be conducted while the member is wearing a weighted vest or SCBA airpack.
- (3) The member being tested shall complete all stations in the time set as the standard.
- (4) The evaluation shall be scheduled and conducted by the Fire Chief or his designee. The test will be scheduled at least four (4) times throughout the year.
- (5) Any member who fails to meet the minimum physical performance requirements in a calendar year for any reason shall be considered unfit for emergency operations.

- (B) **Failure to Meet Requirements.** Members who cannot meet the minimum requirements of the medical or physical evaluations in any calendar year will be allowed to take such paid sick days and/or vacation leave as the member has available and, thereafter, FMLA leave until the member is able to return to duty. If, after the exhaustion of paid sick days/vacation leave and unpaid FMLA, the member is still unable to return to duty, then the member will be terminated.

Article 22 – Miscellaneous.

- (A) **Pay Day.** Employees shall be paid biweekly, every other Friday. When a regular pay date falls on a holiday, employees will receive their pay on the last workday before the regularly scheduled pay day. Employees may choose direct deposit of their paycheck in the banking institution of their choice or to have a paycheck issued to them. Those who choose direct deposit will receive an itemized statement showing the current wage statement and the current year cumulative wage statement. A net deposit will be made into one (1) designated banking institution in its entirety and will not be split in any manner by the Village. Paychecks for those who do not use direct deposit will be made available in the office of the secretary of the Village Administrator by noon on pay day. Direct deposit forms are available from the secretary of the Village Administrator.

- (B) **Address and Personal Status Change.** Each Village employee has a permanent personnel file. Employees shall fill out the personal data forms provided by the Village from time to time and this information will become part of the employee's permanent personnel file. The Employee shall keep the Village Clerk/Treasurer advised of changes in address, telephone number, change of name or marital status. This information is used only to forward necessary information or to contact the employee when it is necessary for the Village to do so. It is the Village's policy to protect the privacy of each employee. Employees may inspect information in his/her own personnel records and files in order to ensure accuracy. Should an employee desire to see his/her file, a request must be made in writing to the Village Clerk/Treasurer. The employee may then review the file in the presence of the Village Clerk/Treasurer.
- (C) **Parking.** Parking is available on the premises of the Village's facilities and is available for each employee. Except in the event of an act of negligence by a Village employee, agent or representative while working for the Village, the Village is not responsible for any damage to an employee's vehicle or its contents. Parking in reserved spaces is prohibited at all times. No unauthorized vehicles shall be parked upon Village property. No "for sale" signs shall be displayed on or adjacent to parked vehicles.
- (D) **Safety and Equipment.** The Village and the Union agree to cooperate in the ongoing objective to take all required measures to eliminate accidents and health hazards. The Village shall continue to make reasonable and necessary provision for the safety and health of employees. Suggestions and recommendations of the employees shall be received and considered by the Village in developing and maintaining such safety program as is deemed appropriate.
- (E) **Applicable Laws.** This Agreement shall be construed in accordance with the laws of the State of Wisconsin.
- (F) **Modification and Execution in Counterparts.** This Agreement may be executed by the signators hereto in one or more originals by the undersigned representatives of the parties hereto. By executing this contract at the space indicated below, each of the signators hereby warrants and represents to the other that such signator has full authority to bind his or her principal to the terms and conditions of this Agreement without requiring the other party to look beyond the terms of this Agreement to determine the authority of such signator to bind its principal. In the case of the Village, the undersigned representatives of the Village hereby warrant and represent that this Agreement was approved by a majority of a quorum at a duly noticed and conducted meeting of the Village Board of the Village; furthermore, no modification of this Agreement may take place unless it is in writing and approved under the same standards as was required for the approval by the principals to this Agreement of the original agreement.

- (G) **Severability.** If any article or section of this Agreement shall be held invalid by operation of law or by any tribunal of competent jurisdiction, or if compliance with or enforcement of any article or section should be restrained by such tribunal pending determination as to its validity, the remainder of this Agreement and the application of such article or section to persons or circumstances other than those as to which it has been held invalid or as to which compliance with or enforcement of has been restrained, shall not be affected thereby. If a provision of this Agreement is held to be invalid, and it is lawful to negotiate an alternative provision that would be valid, the parties will enter into negotiations within thirty (30) days for the purpose of attempting to arrive at a mutually satisfactory replacement for such provision.
- (H) **No Precedent.** In entering into this settlement, neither the Village nor the Union makes any admission, or waives any argument(s) or defense(s) with respect to any pending dispute over the meaning or application of the predecessor Collective Bargaining Agreement.

Dated at Somers, Wisconsin, this _____ day of _____, 202__.

VILLAGE OF SOMERS

By: _____
George Stoner, President

Attest: _____
Brandi Baker, Clerk/Treasurer

Dated at Somers, Wisconsin, this _____ day of _____, 202__.

VILLAGE OF SOMERS, LOCAL 4831

By: _____
_____, Its duly authorized representative

By: _____
_____, bargaining committee member

By: _____
_____, bargaining committee member

By: _____
_____, bargaining committee member

VILLAGE OF SOMERS

LOCAL UNION NAME: _____ No. _____

Employer: _____

Complaint and Grievance No. _____ Date _____

Employee's Supervisor _____ Work Location _____

Employee's Name _____ Hiring Date _____

Employee's Phone _____ Grade Level _____

Date of the alleged infraction _____

Statement of Grievance:

(Circumstances of Facts): (Briefly, what happened) _____

(The contention—what did management do wrong?)(Article or Section of contract which was violated if any) _____

(The Request for Settlement or corrective action desired): _____

(Signed) _____

EXHIBIT "A"

Employees Whose Start Date Was On Or Before 10/31/14

Year	Start	6 Months	24 Months	48 Months	60 Months
20203	n/a	n/a	n/a	n/a	\$27.15
20214	n/a	n/a	n/a	n/a	\$28.23
20225	n/a	n/a	n/a	n/a	\$29.07

Employees Whose Start Date Was On Or After 11/1/14

Year	Start	12 Months	36 Months	48 Months	60 Months	84 Months
2023	\$18.23	\$20.00	\$21.78	\$23.70	\$25.63	\$27.15
2024	\$18.95	\$20.80	\$22.65	\$24.64	\$26.65	\$28.23
2025	\$19.51	\$21.42	\$23.32	\$25.37	\$27.44	\$29.07

EXHIBIT "B"

Somers Fire Department Physical Agility Test Release/Hold Harmless

Candidate Name (please print)

____/____/____
Test Date

I, _____, am interested in becoming a member of Somers Fire Department and agree to participate in a physical agility test consisting of pulling, climbing, lifting, and carrying of equipment.

I do realize there is a possibility of being injured while participating in this test and hereby release and hold harmless the Village of Somers, Somers Fire Department, Somers Rescue Squad, Each of Their Officers, Employees, or their representatives from any claim for injury or damages resulting from or connected with my participation in this test.

Physical Agility Test

Candidates/Members taking test will wear gloves, and a 50 lb. weighted vest to simulate the weight of fire-fighting equipment. The candidate/member must pass all stations without exceeding the maximum allowed time of **8 minutes (2 minutes for the warm-up + 6 minutes for the remainder of the course)**. The candidate/member must walk between stations. Once the candidate/member begins this test, he/she must continue until finishing all of the stations or exceeding the maximum time allowed. If the candidate/member is unable to complete any of the stations, he/she may withdraw from the physical agility test at any time. The tester may also stop the test due to unsafe actions.

Aerial Ladder Climb: The candidate will climb the aerial ladder fully extended at a 70 degree. The candidate will wear a truck belt for safety. Candidate must climb to the furthest rung and touch the rung or ring a bell and climb back down. This is not a timed test.

Pass / Fail

Warm-up Station: Candidate/member will walk on a treadmill at a 0% grade at 3.5mph for 2 minutes. *Candidate must not touch the handrails and will receive one warning, after the second touch candidate will be disqualified and the test will be stopped. After the 2 minutes are finished, the candidate will be asked to step off to the sides of the treadmill and wait for the treadmill to stop before proceeding to the next station (station #1).*

Pass / Fail

Station #1 (Hose carry/stair climb): *After completing the warm-up the candidate/member will proceed to the stairs and the time will start when candidate picks up a 2-1/2" hose pack and carry the hose-pack in any manner to the top of the stairs and bring hose-pack back down. The candidate will have 6 minutes for the remainder of the course. The candidate/member will then proceed back up the stairs in the same manner and repeat this process a total of 4 times. After the 4th climb, candidate must place hose-pack back in the starting location. The candidate/member may take multiple steps while proceeding up the stairs, but candidate/member must touch every step while coming down the stairs. At least one hand should be in contact with the hand rail at all times, while proceeding up and down the stairs. Failure to use the handrail while climbing the stairs will be considered an unsafe act and will count as a failure.*

Pass / Fail

Station #2 (Simulated equipment Carry): The candidate/member will pick up two 30 lb. weights, one in each hand, and carry them while walking fifty (50') feet around the cone, then back to the starting point. You are permitted to place the weight(s) on the ground and adjust your grip. Upon completion place the weights on the ground back in their original location.

Pass / Fail

Station #3 (Forcible Entry): Using the 10-lb. sledge hammer provided, the candidate/member must drive the sled; a 75-lb. steel beam a horizontal distance of 4-ft. until the beams strikes the opposite side. **Pushing, raking or hooking the beam is not allowed; only the head of the mallet is allowed to strike the beam. The handle must not come in contact with the beam at any time. Both hands must be above the tape mark on the handle (12-in. from the top, head end) at the point of impact.** The hammer must be placed down in designated area next to sled upon completion.

Pass / Fail

Station #4 (Hose Drag): The candidate/member will advance (3) connected/ uncharged sections of 2-1/2" hose-lines straight a distance of fifty (50') feet, make a right turn passed a barrel and proceed another twenty-five (25') feet to the finish line, drop to one knee and pull the hose until the first coupling crosses the finish line. You are permitted to run during the hose drag.

Pass / Fail

Station #5 (Simulated Ceiling Pull): The candidate/member will pull down weight attached to a rope, weighted with a fifty (50-lb.) pound weight. Candidate/member must pull down **10** times and weight must go above the line on the machine at the test station and must touch lower line on the machine. **Weight must not touch the weight stack between each pull down. Failure to go above the line will not count and tester will tell the candidate/member that it did not count.**

Pass / Fail

Station #6 (Rescue Victim): The candidate/member must grasp a 125-lb. mannequin by the handle(s) on the shoulder(s) of the harness (either one or both handles are permitted), drag it fifty (50') feet , make a 180 degree turn around the beam, and continue an additional fifty (50') feet to the finish line. **You are not permitted to grasp or rest on the cone. You are permitted to drop and release the mannequin and adjust your grip. The entire mannequin must be dragged until it crosses the marked finish line. This concludes the Physical Agility test and your time will stop upon completion.**

Pass / Fail

Candidate signature

_____/_____/_____
Date

Tester/Officer signature

_____/_____/_____
Date

Physical Agility Test Time: _____

Pass / Fail _____
Candidate's Initials

Notes: _____

Revised (3/30/2015)

EXHIBIT "C"

SOMERS FIRE & RESCUE

CHIEF
Carson Wilkinson

P.O. Box 197
Somers, WI 53171
(262-859-2277)



2017- 2019 Vacation Selection

1. Selection will be by seniority.
2. Each person will pick up to three days on the first round, and up to six on the second round and subsequent. The days carried over from the previous year will also be picked in the first round.
(Carry over days from the previous year must be used by April 1st, unless preapproved by the Fire Chief)
3. Only one person will be allowed off per shift for vacation.
4. At the end of the year you can carry over up to three days into the next year without supervisory approval.
5. Up to two days a year may be broken into partial days of not less than 2 hours off per day.

Exhibit "C"

Exhibit "D"

Lieutenant shall be paid \$1,500.00 annually. This will be paid out over each pay period. Each two week pay period will have \$57.70 marked as officer pay.

Captain shall be paid \$2,000.00 annually. This will be paid out over each pay period. Each two week pay period will have \$76.92 marked as officer pay.

Training Captain shall be paid \$5,300.00 annually. This will be paid out over each pay period. Each two week pay period will have \$203.85 marked as officer pay.

Exhibit “E”

Acting Chief Duties and Responsibilities

Duties

- Responding to Somers calls as a command officer per response SOG
- Responding to mutual aid calls
- Receive phone calls for call offs of shifts
- Fill spots in the schedule caused from sick leave or absences
- Any other scene related tasks normally performed by the Chief like press interviews

Notify the Fire Chief of any of the following events

- Significant injuries or death to a department member
- Damage to equipment greater than \$500.00 in value
- Any other situation they feel exceeds the scope of any Acting Chief
- Any incident that would be classified as a disaster or any need to activate emergency management for the Village

Work rules

- Monday - Friday (non-holidays) Acting Chief is expected to be at one of the Somers Fire Stations during the hours of 0800 - 1630 but allowed to leave for meals or work related events. Hours outside of 0800 - 1630 can be worked from offsite locations within 10 miles of Somers.
- Saturday/Sunday/Holidays – Acting Chief can work from offsite locations within 10 miles of Somers
- Acting Chief must always be available by phone when performing the role of Acting Chief
- Acting Chief must abide by all Somers Fire & Rescue policies, procedures and SOGs even when working from offsite

**VILLAGE OF SOMERS
VILLAGE BOARD
MEETING ITEM MEMORANDUM**

MEETING DATE: December 13th, 2022

TO: Village President Stoner and Village Trustees

PREPARED BY: Jason J. Peters, Administrator

AGENDA ITEM: #11 Discussion and possible action on request from Stream Realty for the removal of the condition precedent stating that “Developer entering into a Memorandum of understanding with Kenosha County for the construction of offsite public infrastructure” from Stream Realty’s October 11th, 2022 approvals for rezoning, site plan and exterior fenestration, and developer’s agreement for Tax Parcel #s 82-4-222-194-0101, 82-4-222-301-0050, 82-4-222-301-0040 & 82-4-222-301-0030, located in the SE ¼ of Section 19 and the NE ¼ of Section 30, T2N, R22E, Village of Somers”

BACKGROUND:

The Village began working with Stream Realty in late 2021 regarding their desire to bring a “Class A” warehousing/industrial project to approximately 90 acres (82-4-222-194-0101, 82-4-222-301-0030, 82-4-222-301-0040, 82-4-222-301-0050) located on CTH S, west of the recently approved HSA project. Phase I would bring a 612,252 sq. ft building. Phase II would bring two smaller buildings. In total, the Project would bring three buildings totaling 935,000 sq. ft. of warehousing/manufacturing space. These buildings are being built as “spec” buildings.

At our October 11th Board Meeting, the Board approved the following:

- Rezoning from A-1 Agricultural Preservation Dist., A-2 General Agriculture Dist., R-2 Suburban Single Family Residential Dist., R-3 Urban Single-Family Residential Dist. to BP-1 Business Park Dist. PUD Planned Unit Development Overlay Dist.
- Site Plan and Exterior Fenestration approval; and
- The developer’s agreement between the Village of Somers and Stream Realty for a Proposed Planned Unit Development known as Somers Business Park.

During this process the County was working with Stream allowing trucks to exit onto CTH S and enter the property with “left in” crossing CTH S. To allow this the County requested that Stream Realty enter into a Memorandum of Understanding on how these accesses will be constructed. The following condition precedent was added to each approval due to the fact the Developer was still working with the Kenosha County Highway Department on their access to the site:

- *Subject to Developer entering into a Memorandum of understanding with Kenosha County for the construction of offsite public infrastructure.*

Stream has been working with Pinnacle Engineering and the County to develop this memorandum of understanding. Stream does not have a full memorandum of understanding completed with the County at this time and risk missing their closing date with their sellers. Early last week, Stream contacted Administrator Peters to inquire as to whether the above condition precedent could be removed from their approvals so that their underwritings would allow for them to close on the properties. Administrator Peters, Attorney Davison and Highway Commissioner Abongwa have worked with Stream to find a way to remove this condition. A letter executed by the County lays out the conditions that will get Stream to a formal memorandum of understanding with the County.

PRIOR ACTION TAKEN:

The possibility of putting this item on the agenda was discussed at our December 6th Work Session under the review of tentative agenda.

SUGGESTED ACTION/ACTION REQUESTED/COMMENTS:

Based on this letter, Attorney Davison is comfortable with removing the above referenced condition precedent. Most importantly, Stream has been informed that they will not receive building permits until the County’s requirements are met. In the event that the Village Board agrees with removing the condition precedent from Stream Realty’s October 11th approvals, a suggested motion to approve would be as follows:

“Motion to approve the removal of the condition precedent stating that “Developer entering into a Memorandum of understanding with Kenosha County for the construction of offsite public infrastructure” from Stream Realty’s October 11th, 2022 approvals for rezoning, site plan and exterior fenetraion, and developer’s agreement for Tax Parcel #s 82-4-222-194-0101, 82-4-222-301-0050, 82-4-222-301-0040 & 82-4-222-301-0030, located in the SE ¼ of Section 19 and the NE ¼ of Section 30, T2N, R22E, Village of Somers”

ATTACHMENTS:

Kenosha County Letter dated 12/08/2022



COUNTY OF KENOSHA

Shelly Billingsley, Director
Department of Public Works & Development Services

Clement Abongwa, Director
Division of Highways
19600 75th Street, Suite 122-1
Bristol, Wisconsin 53104
(262) 857-1870
Fax: (262) 857-1885

December 8, 2022

SRPF D/Burlington Rd, L.L.C.
Stream Realty Partners
2001 Ross Avenue, Suite 400
Attention: Dale Todd

Dear Mr. Todd:

Kenosha County understands that SRPF D/Burlington Rd, L.L.C., an affiliate of Stream Realty Acquisition, LLC (the "**Developer**"), is the contract purchaser of a property commonly known as the "Grohs property" (the "**Property**") located on County Trunk Highway "S" (the "**County Road**") in the Village of Somers, Wisconsin. The Developer desires to construct on the Property a distribution and warehousing facility consisting of three buildings and related improvements (the "**Proposed Development**"), which has been conditionally approved by the Village. In connection with the Proposed Development, the Developer desires to construct two connections to the County Road, which will include the construction of the following improvements located within the County Road right-of-way: (1) two new driveways connecting the County Road to one new public road and one new private road that will be constructed on the Property as part of the Proposed Development; (2) a westbound right turn lane into the proposed public roadway access; and (3) an eastbound left turn lane with a median opening. These improvements are depicted on **Exhibits A and B** attached to this letter.

On September 19, 2022, the County's Director of Highways issued a review letter stating that "the conceptual layout of the public roadway and west driveway accesses" along the County Road "have been considered satisfactory and approved", with the following comments:

1. Public roadway access shall be characterized by right-in/right-out and eastbound left-in only. A median opening shall be permitted to accommodate eastbound left turn movement.
2. West driveway access shall be characterized by right-in/right-out only.
3. The west driveway access shall be dedicated for passenger vehicles only. No ingress nor egress truck traffic is permitted to use the west driveway access.
4. A dedicated westbound right-turn lane is required for the proposed public roadway access.
5. Both public roadway access and west driveway shall intersect at right angle with CTH S.
6. A comprehensive access design plan shall be developed by a licensed Kenosha/WisDOT approved design consultant. The plan developed shall be reviewed and approved by the County.

7. Concrete curb and gutter is not permitted within the highway right-of-way.
8. The County and the developer shall execute a memorandum of understanding in which the prosecution of the design and construction of the accesses to Grohs property shall be clearly outlined.
9. A driveway permit is required prior to constructing both accesses to the Grohs property.

Kenosha County acknowledges that Comments 1 – 5 and 7, above, have been addressed by the Developer in Exhibits A and B attached to this letter. The County understands that the Developer also intends to address Comments 1 – 5 and 7 in the comprehensive access design plan required by Comment 6, above, in substantial accordance with Exhibits A and B attached to this letter.

The County further understands that the Developer: (a) has engaged a licensed Kenosha/WisDOT approved design consultant, who is in the process of preparing the comprehensive access design plan for review and approval by the County, as required by Comment 6, above; (b) is in the process of preparing the memorandum of understanding for consideration by the County and is prepared to enter into a mutually acceptable final memorandum of understanding with the County, as required by Comment 8, above; and (c) will obtain from the County a driveway permit before constructing both accesses to the Grohs property, as required by Comment 9, above.

This letter affirms that the County has reviewed and concurs with the conceptual layout of the proposed right-of-way improvements depicted on Exhibits A and B attached to this letter, subject to approval by the County of the final comprehensive access design plan, as required by Comment 6, the execution by the Developer and the County of a memorandum of understanding, as required by Comment 8, and the issuance by the County of a driveway permit before construction of the right-of-way improvements begins, as required by Comment 9.

Sincerely,



THESE PLANS AND DESIGNS ARE COPYRIGHT PROTECTED AND MAY NOT BE USED IN WHOLE OR IN PART WITHOUT THE WRITTEN CONSENT OF PINNACLE ENGINEERING GROUP, LLC

REVIEWED: TOM

DESIGNED: JMS

DRAFTED: JMS

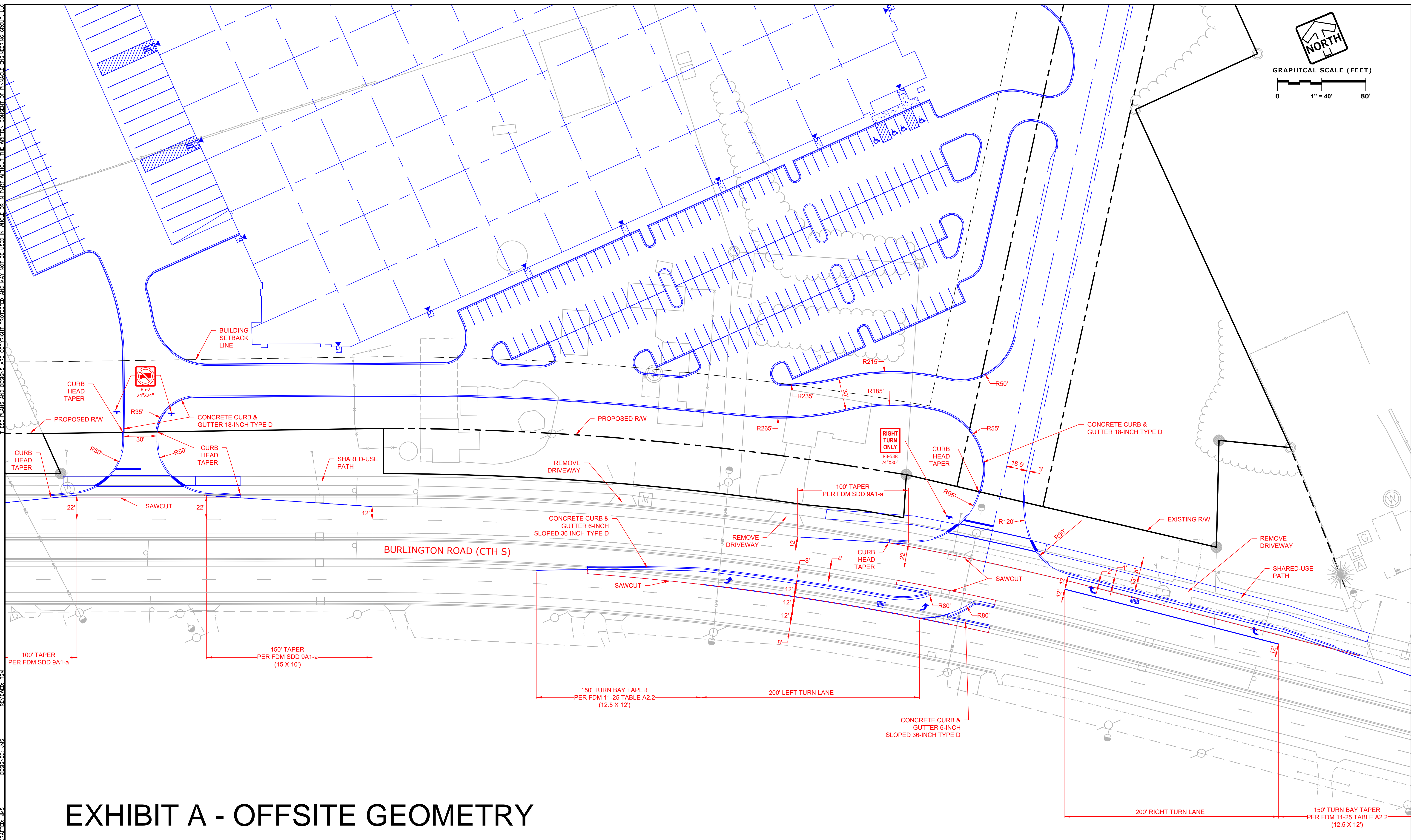
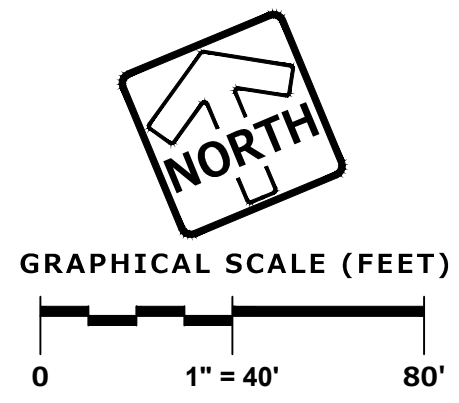

EXHIBIT A - OFFSITE GEOMETRY

PLAN | DESIGN | DELIVER
www.pinnacle-engr.com

PINNACLE ENGINEERING GROUP
ENGINEERING | NATURAL RESOURCES | SURVEYING

WISCONSIN OFFICE:
20725 WATERTOWN ROAD, SUITE 100
BROOKFIELD, WI 53186
(262) 754-8888

CHICAGO | MILWAUKEE | NATIONWIDE

SOMERS BUSINESS PARK

BURLINGTON ROAD GEOMETRY

KENOSHA COUNTY

BURLINGTON ROAD GEOMETRY

REVISIONS	

REG. JOB No. 2360.00
REG. PH. IGM
START DATE 11-30-22
SCALE 1"=40'

SHEET
EX-1
OF
EX-1

© COPYRIGHT 2021

Z:\PROJECTS\2021\2360.00-W\CAD\EXHIBITS\DEVELOPMENT AGREEMENT EXHIBITS\2360.00-WI EXHIBIT F TYPICAL SECTION.DWG 9/27/2022 12:17 PM

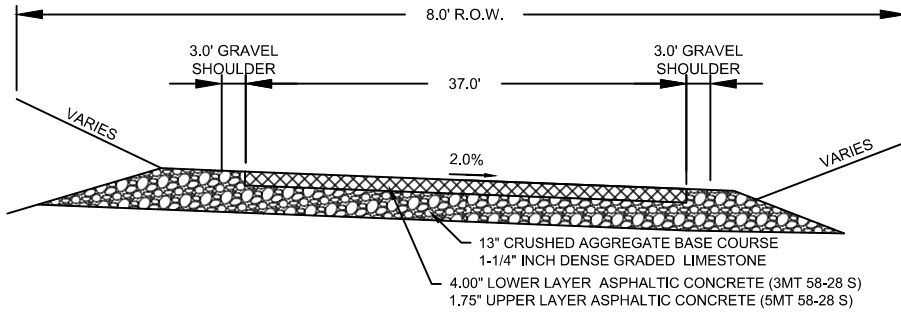

TYPICAL FINISHED SECTION
PUBLIC ROAD

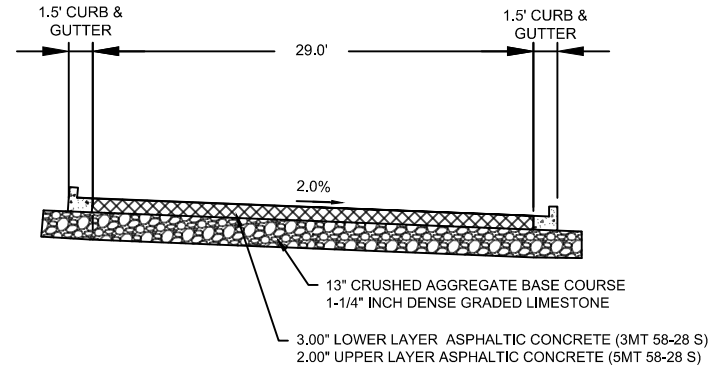

TYPICAL FINISHED SECTION
PRIVATE ROAD

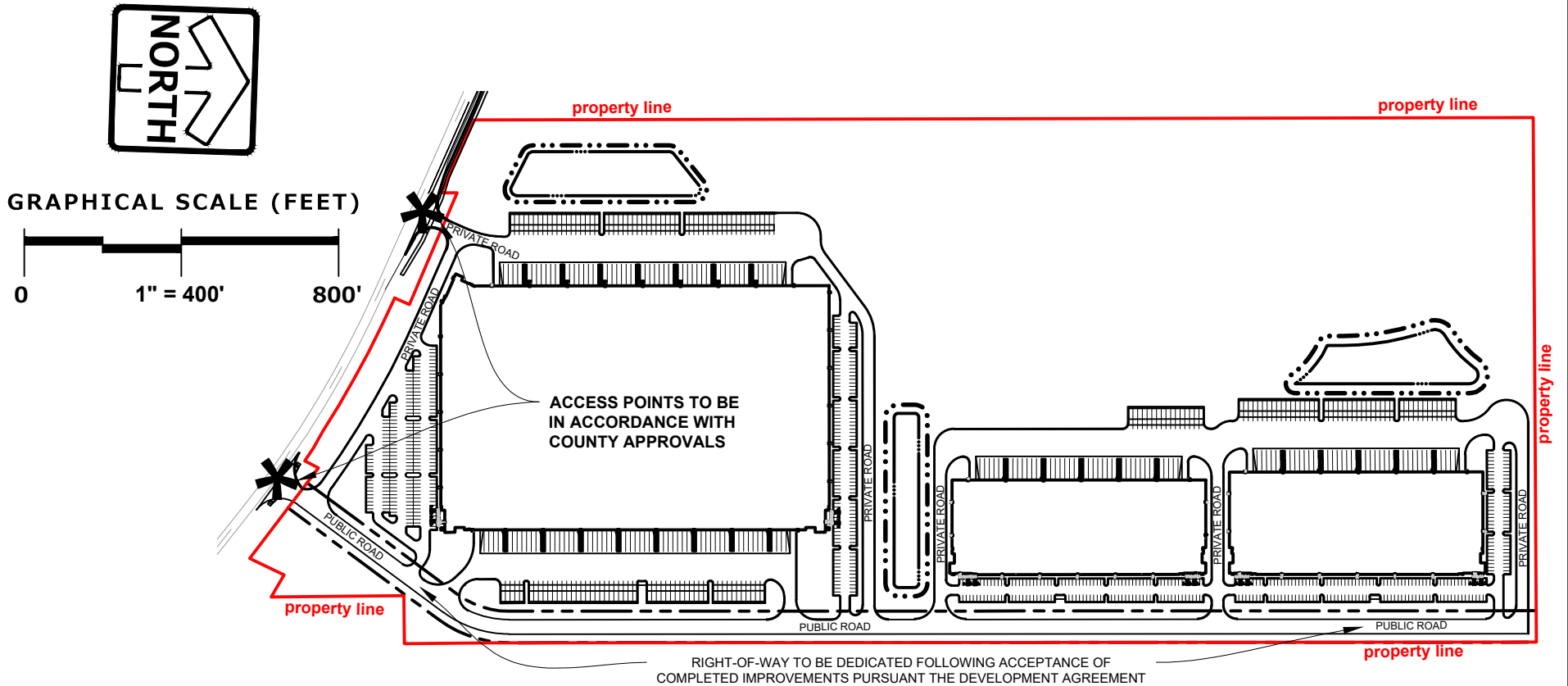

EXHIBIT "B" - ROAD PLAN

PINNACLE ENGINEERING GROUP

20725 W. WATERTOWN RD | SUITE 100 | BROOKFIELD, WI 53186 | WWW.PINNACLE-ENGR.COM | 262-754-8888

09/29/2022

PLAN | DESIGN | DELIVER

PEG JOB# 2402.00



**VILLAGE OF SOMERS
VILLAGE BOARD
MEETING ITEM MEMORANDUM**

MEETING DATE: December 13th, 2022

TO: Village President Stoner and Village Trustees

PREPARED BY: Jason J. Peters, Administrator

AGENDA ITEM: #12 Action on request from Tyler and Deleen Nehls for Release of Conservation Easement on Tax Parcels # 83-4-223-064-0213 & 83-4-223-064-0214 (507 13t Avenue)

BACKGROUND:

Planning and Administration has been working with the Nehls for some time on their desire to build a house on their property on 13th Avenue. As a part of this process, the Village did a site visit. Mr. Nehls explained that there was a conservation easement placed on the CSM that split the original lot. Lots 1 and 2 have since been combined by the Nehls. The Nehls would like to remove the conservation easement on Lot 3 so that a portion of their now combined lot can be sold to their neighbors, the Bonns. The Nehls' Attorney Anthony Nudo has prepared the required documents and submitted them to the Village. Attorney Davison has reviewed both the documents and the process to remove said easements.

PRIOR ACTION TAKEN:

This matter was reviewed and discussed at our December 6th Work Session.

SUGGESTED ACTION/ACTION REQUESTED/COMMENTS:

Attorney Davison has reviewed both the documents and the process to remove said easements and has no issues. Administrator Peters has no objections to the request. In the event that the Village Board agrees with the suggested action, a suggested motion to approve would be as follows:

“Motion to approve request from Tyler and Deleen Nehls for Release of Conservation Easement on Tax Parcels # 83-4-223-064-0213 & 83-4-223-064-0214”

ATTACHMENTS:

Letter from Attorney Nudo

Proposed Release of Easement

2007 Record CSM

Lot 3 with Current Easement Noted

Map of Area

December 1, 2022

VIA EMAIL ONLY

Jason Peters, Village Administrator
Village of Somers
7511 12th Street
PO Box 197
Somers, WI 53171

Re: Release of Restrictions – Conservation Easement at 507 13th Ave, Somers, WI

Dear Mr. Peters:

I am assisting Tyler and Deleen Nehls, the owner of referenced property, and their neighbors, Tony and Patricia Bonn (through their son, Marc Bonn), in obtaining a release of a conservation easement on the Nehls property. I write to provide you the history of the conservation easement and the reason we ask to be released from the same.

The Nehls purchased the subject property, which contains 14.57 acres, from Sands and Marianne Ruffalo in 2020. The Ruffalos formerly lived at the property. In 2006 or 2007, the Ruffalos lost their house in a fire. In 2007, the Ruffalos petitioned the County and then-Town of Somers to divide the 14.57 acres into three separate lots. As is typical in a land division, the Ruffalos engaged their neighbors for feedback. The Bonns requested a “conservation easement” be placed between their property and the adjoining Ruffalo lot to ensure that no accessory structures would be built on that portion of the land (i.e. a garage or pole barn). The Ruffalos and government agencies agreed to this request.

In 2020, following the purchase of all three lots, the Nehls combined Lot 1 and Lot 2 to build their homestead. The conservation easement is on Lot 3. The Bonns desire to purchase a portion of Lot 3 from the Nehls and the Nehls desire to sell it to the Bonns. The parties propose that the portion of land be attached to the Bonn property. That portion of land contains a portion of the conservation easement. The Bonns would like to use the purchased land for their recreation, including possibly building a gazebo or adding a bird feeder. That activity would be prohibited if the conservation easement remains.

The conservation easement was placed for the Bonns’ benefit. The need for the conservation easement is moot upon the Bonns purchasing that portion of land. The parties mutually request that the Village of Somers approves the release of restrictions and executes the enclosed instrument for recording with the Register of Deeds.

Mr. Peters
Village of Somers
December 1, 2022
Page 2

Sincerely,

TERRY & NUDO, LLC

A handwritten signature in black ink, appearing to read 'AN', is written over the company name.

Anthony Nudo

AN/klb
c.c. Nehls and Bonn

RELEASE OF RESTRICTIONS

CONSERVATION EASEMENT

Document Number

Document Title

WHEREAS, in conjunction with land division activities conducted in the Town of Somers (now the Village of Somers) in 2007 and years before and after that date, the property owner and subdivider of land included within Kenosha County Certified Survey Map No. 2597, recorded in the office of the Kenosha County Register of Deeds as Document No. 1538458, sought to divide land as contemplated in such certified survey map;

WHEREAS, a conservation easement was created as it appears on the face of Kenosha County Certified Survey Map No. 2597;

WHEREAS, the following note appears on the face of Kenosha County Certified Survey Map No. 2597:

No improvements shall be permitted in the conservation easement area and all existing vegetation shall remain in its natural state, with the exception of non-native species which may be removed.

Recording Area

Name and Return Address

Terry & Nudo, LLC
c/o Atty. Anthony Nudo
600 52nd Street, Suite 320
Kenosha, WI 53142

83-4-223-064-0213

83-4-223-064-0214

Parcel Identification Number (PIN)

WHEREAS, such conservation easement and note shown on the face of the certified survey map was a restriction for public benefit, pursuant to Wis. Stat. §§ 700.40 and 236.293, and therefore may be released or waived in writing by the Village of Somers;

WHEREAS, circumstances have changed substantially from the time that Certified Survey Map No. 2597 was approved, to date;

WHEREAS, the Village of Somers hereby intends to release the Village's interest in the conservation easement and note; and

WHEREAS, the Village of Somers makes no representations as to rights held by others.

NOW, THEREFORE, the Village Board of the Village of Somers, Kenosha County, Wisconsin, hereby releases its interest in the conservation easement and following note from Kenosha County Certified Survey Map No. 2597:

No improvements shall be permitted in the conservation easement area and all existing vegetation shall remain in its natural state, with the exception of non-native species which may be removed.

Dated this ____ day of _____, 202__.

VILLAGE OF SOMERS

George Stoner, Village President

ATTEST:

Brandi Baker, Village Clerk

STATE OF WISCONSIN)
) ss.
COUNTY OF KENOSHA)

Personally came before me on this ____ day of _____, 202__, the above-named George Stoner, Village President, and Brandi Baker, Village Clerk, executed the foregoing instrument and acknowledged the same.

NOTARY PUBLIC, STATE OF WI
My Commission Expires: _____

DRAFTED BY:



TERRY & NUDO, LLC

Anthony Nudo, Attorney at Law

SBN: 1055242

600 52nd Street, Suite 320

Kenosha, WI 53140

Telephone: (262) 842-2338

Facsimile: (262) 584-9949

Email: Anthony@LawMidwest.com



Stock No. 26273

Doc # 1538458

CERTIFIED SURVEY MAP NO. 2597

BEING A PART OF THE NORTHWEST 1/4 OF THE SOUTHEAST 1/4 OF SECTION 6, TOWNSHIP 2 NORTH, RANGE 23 EAST OF THE FOURTH PRINCIPAL MERIDIAN, IN THE TOWN OF SOMERS, COUNTY OF KENOSHA AND STATE OF WISCONSIN.

OWNER/SUBDIVIDER: SANDS J. JR. AND MARIANNE RUFFALO
507 13TH AVENUE
RACINE, WI 53403-9656

PREPARED BY: B.W. SURVEYING, INC.
412 N. PINE STREET
BURLINGTON, WI 53105
(262)-767-0225
JOB NO. 7543-CSM

LEGEND

- ⊕ FOUND BRASS CAPPED CONCRETE MONUMENT
- FOUND 3/4" O.D. IRON PIPE
- ∅ FOUND 1" O.D. IRON PIPE
- ⚡ FOUND 3/4" DIA. IRON ROD
- SET 1-5/16" O.D. X 18" IRON PIPE WEIGHING NOT LESS THAN 1.13 POUNDS PER LINEAL FOOT.
- ⊙ SET 2-3/8" O.D. X 18" IRON PIPE WEIGHING NOT LESS THAN 3.65 POUNDS PER LINEAL FOOT.
- SET MASONRY NAIL IN ASPHALT DRIVE

NOTE: LOTS 1, 2, AND 3 OF THIS CERTIFIED SURVEY MAP SHALL BE SERVED BY PUBLIC SANITARY SEWER AND SHALL BE RESTRICTED FROM ANY FURTHER DIVISION.

NOTE: NO IMPROVEMENTS SHALL BE PERMITTED IN THE CONSERVATION EASEMENT AREA. AND ALL EXISTING VEGETATION SHALL REMAIN IN ITS NATURAL STATE, WITH THE EXCEPTION OF NON-NATIVE SPECIES WHICH MAY BE REMOVED.

NOTE: THERE SHALL BE NO FILLING, EXCAVATION OR BUILDING WITHIN THE WETLAND AREA.

GRAPHIC SCALE

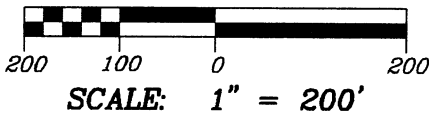

CENTER OF SECTION 6-2-23
N. = 248,363.87
E. = 2,584,732.56

EAST 1/4 CORNER SECTION 6-2-23
N. = 248,452.54
E. = 2,587,364.08

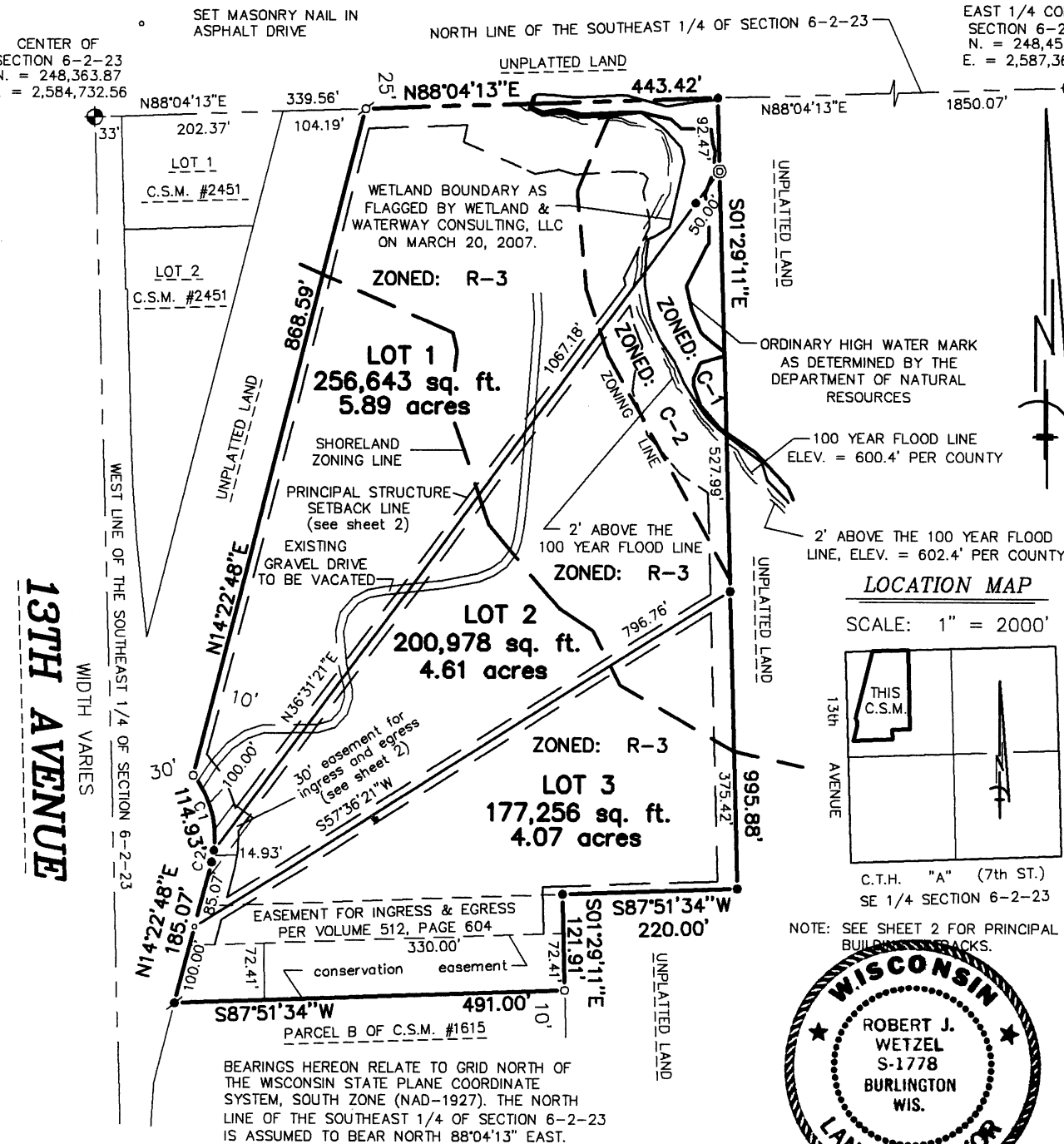

13TH AVENUE
WIDTH VARIES

LOCATION MAP

SCALE: 1" = 2000'

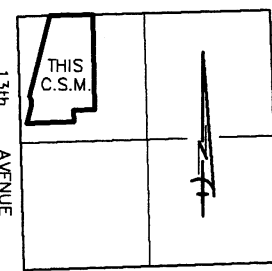

C.T.H. "A" (7th ST.)
SE 1/4 SECTION 6-2-23

NOTE: SEE SHEET 2 FOR PRINCIPAL BUILDINGS.

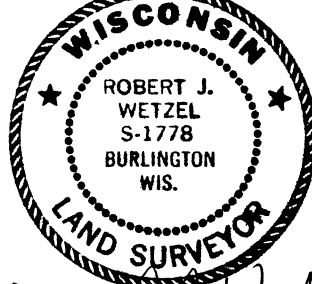

Robert J. Wetzel
ROBERT J. WETZEL S-1778
APRIL 5, 2007
REVISED: AUGUST 7, 2007
REVISED: AUGUST 21, 2007

CURVE TABLE					
CURVE	LENGTH	RADIUS	DELTA ANGLE	CHORD BEARING	CHORD
C1	100.00'	124.16'	46°08'51"	N15°35'47"W	97.32'
C2	14.93'	124.16'	06°53'21"	N10°55'22"E	14.92'
OVERALL	114.93'	124.16'	53°02'18"	N12°09'04"W	110.87'



Stock No. 26273

Doc # 1538458

CERTIFIED SURVEY MAP NO. 2597

BEING A PART OF THE NORTHWEST 1/4 OF THE SOUTHEAST 1/4 OF SECTION 6, TOWNSHIP 2 NORTH, RANGE 23 EAST OF THE FOURTH PRINCIPAL MERIDIAN, IN THE TOWN OF SOMERS, COUNTY OF KENOSHA AND STATE OF WISCONSIN.

GRAPHIC SCALE

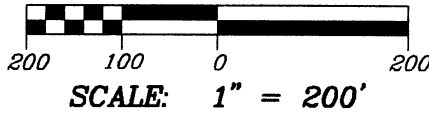

DETAIL OF SETBACKS AND EASEMENTS

R-3 SETBACKS

- STREET = NOT LESS THAN 30 FEET
- SIDE = NOT LESS THAN 10 FEET
- REAR = NOT LESS THAN 25 FEET
- SHORE = NOT LESS THAN 75 FEET FROM ORDINARY HIGH WATER MARK

CENTER OF SECTION 6-2-23
N. = 248,363.87
E. = 2,584,732.56

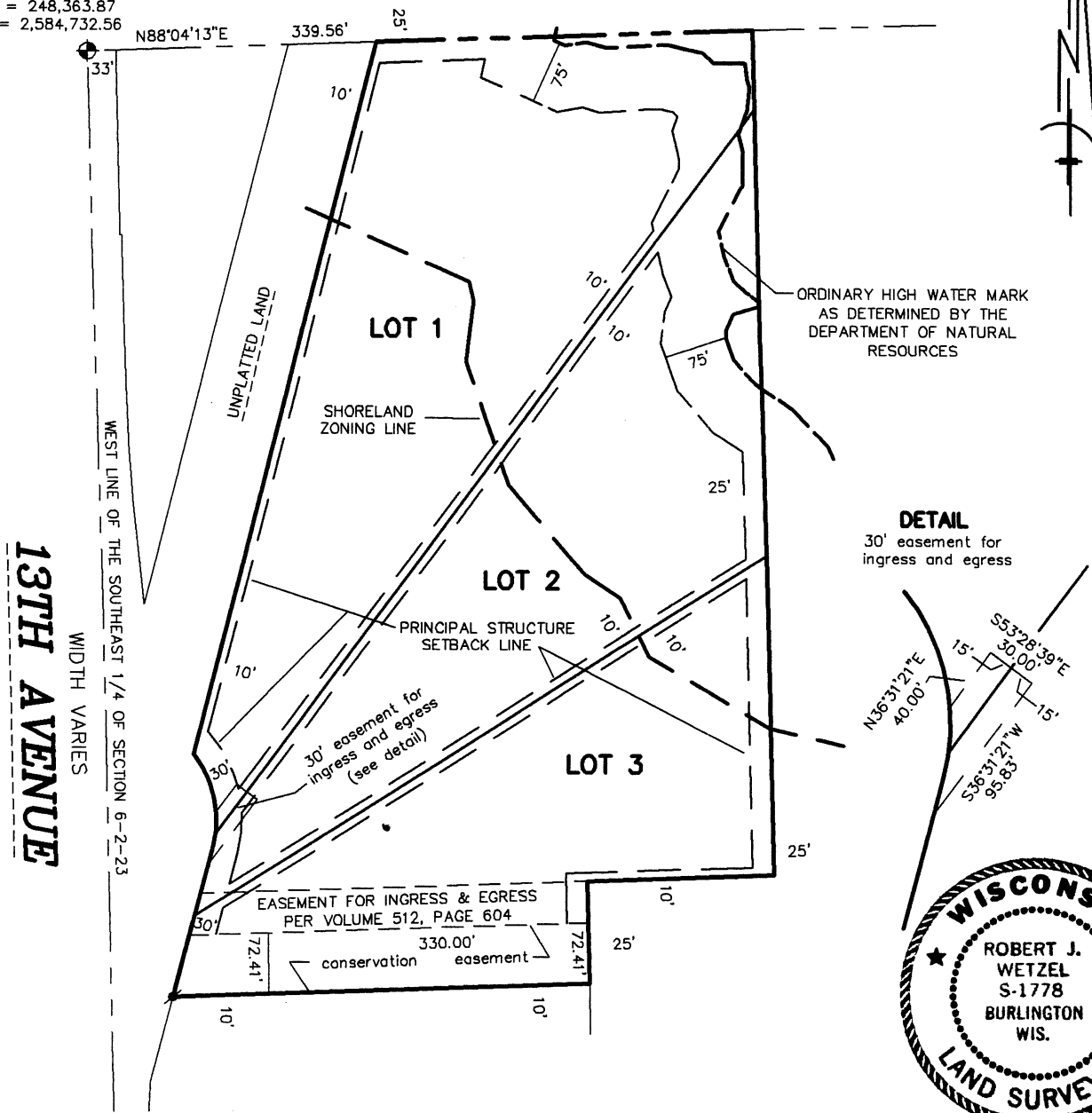

13TH AVENUE

WEST LINE OF THE SOUTHEAST 1/4 OF SECTION 6-2-23
WIDTH VARIES

CURVE TABLE

CURVE	LENGTH	RADIUS	DELTA ANGLE	CHORD BEARING	CHORD
C1	100.00'	124.16'	46°08'51"	N15°35'47"W	97.32'
C2	14.93'	124.16'	06°53'21"	N10°55'22"E	14.92'
OVERALL	114.93'	124.16'	53°02'18"	N12°09'04"W	110.87'

Robert J. Wetzel
ROBERT J. WETZEL S-1778
 APRIL 5, 2007
 REVISED: AUGUST 7, 2007
 REVISED: AUGUST 21, 2007



Stock No. 26273

Doc # 1538458

CERTIFIED SURVEY MAP NO. 2597.

BEING PART OF THE NORTHWEST 1/4 OF THE SOUTHEAST 1/4 OF SECTION 6, TOWNSHIP 2 NORTH, RANGE 23 EAST OF THE FOURTH PRINCIPAL MERIDIAN, IN THE TOWN OF SOMERS, COUNTY OF KENOSHA AND STATE OF WISCONSIN.

LEGAL DESCRIPTION:

BEING PART OF THE NORTHWEST 1/4 OF THE SOUTHEAST 1/4 OF SECTION 6, TOWNSHIP 2 NORTH, RANGE 23 EAST OF THE FOURTH PRINCIPAL MERIDIAN, IN THE TOWN OF SOMERS, COUNTY OF KENOSHA AND STATE OF WISCONSIN AND BEING MORE PARTICULARLY DESCRIBED AS FOLLOWS: COMMENCE AT THE EAST 1/4 CORNER OF SAID SECTION 6; THENCE SOUTH 88°04'13" WEST ALONG THE NORTH LINE OF SAID SOUTHEAST 1/4 SECTION 1850.07 FEET TO THE PLACE OF BEGINNING OF THIS DESCRIPTION; THENCE SOUTH 01°29'11" EAST 995.88 FEET; THENCE SOUTH 87°51'34" WEST 220.00 FEET; THENCE SOUTH 01°29'11" EAST 121.91 FEET; THENCE SOUTH 87°51'34" WEST 491.00 FEET; THENCE NORTH 14°22'48" EAST 185.07 FEET TO A POINT OF CURVATURE; THENCE NORTHWESTERLY 114.93 FEET ALONG THE ARC OF SAID CURVE, BEING A CURVE TO THE LEFT, HAVING A RADIUS OF 124.16 FEET, A CENTRAL ANGLE OF 53°02'18" AND WHOSE LONG CHORD BEARS NORTH 12°09'04" WEST 110.87 FEET; THENCE NORTH 14°22'48" EAST 868.59 FEET TO A POINT ON THE NORTH LINE OF SAID SOUTHEAST 1/4 SECTION; THENCE NORTH 88°04'13" EAST ALONG SAID NORTH LINE 443.42 FEET TO THE PLACE OF BEGINNING. CONTAINING 14.57 ACRES OF LAND MORE OR LESS.

SURVEYOR'S CERTIFICATE:

I, ROBERT J. WETZEL, REGISTERED LAND SURVEYOR, HEREBY CERTIFY THAT AT THE DIRECTION OF SANDS J. JR. AND MARIANNE RUFFALO, I HAVE SURVEYED THE LAND DESCRIBED HEREON AND THAT THE MAP SHOWN IS A CORRECT REPRESENTATION OF ALL LOT LINES AND THAT I HAVE FULLY COMPLIED WITH CHAPTER 236.34 OF THE WISCONSIN STATUTES AND WITH THE SUBDIVISION CONTROL ORDINANCE FOR THE TOWN OF SOMERS, KENOSHA COUNTY, WISCONSIN.

DATED THIS 5TH DAY OF APRIL, 2007.
 REVISED THIS 7TH DAY OF AUGUST, 2007
 REVISED THIS 21ST DAY OF AUGUST, 2007

 ROBERT J. WETZEL S-1778



SHEET 3 OF 4



Stock No. 26273

Doc # 1538458

CERTIFIED SURVEY MAP NO. 2597.

BEING PART OF THE NORTHWEST 1/4 OF THE SOUTHEAST 1/4 OF SECTION 6, TOWNSHIP 2 NORTH, RANGE 23 EAST OF THE FOURTH PRINCIPAL MERIDIAN, IN THE TOWN OF SOMERS, COUNTY OF KENOSHA AND STATE OF WISCONSIN.

OWNER'S CERTIFICATE:

WE, AS OWNERS, HEREBY CERTIFY THAT WE CAUSED THE LAND DESCRIBED ON THIS MAP TO BE SURVEYED, DIVIDED, AND MAPPED AS REPRESENTED HEREON. WE ALSO CERTIFY THAT THIS MAP IS REQUIRED TO BE SUBMITTED TO THE FOLLOWING FOR APPROVAL: TOWN OF SOMERS, KENOSHA COUNTY, WISCONSIN.

Sands J. Ruffalo Jr
SANDS J. RUFFALO, JR.

Marianne Ruffalo
MARIANNE RUFFALO

TOWN OF SOMERS TOWN BOARD APPROVAL:

THIS CERTIFIED SURVEY MAP APPROVED BY THE TOWN BOARD OF THE TOWN OF SOMERS ON THIS 11 DAY OF September, 2007.

James M. Smith
CAROL FISCHER CHAIRMAN
JAMES M. Smith

Timothy J. Kippen
CLERK

KENOSHA COUNTY LAND USE COMMITTEE APPROVAL:

THIS CERTIFIED SURVEY MAP WAS HEREBY APPROVED BY THE KENOSHA COUNTY LAND USE COMMITTEE ON THIS 12th DAY OF September, 2007.

Fred R. Ekornaas
FRED EKORNAAS CHAIRMAN

DATED THIS 5TH DAY OF APRIL, 2007.
REVISED THIS 7TH DAY OF AUGUST, 2007
REVISED THIS 21ST DAY OF AUGUST, 2007

Robert J. Wetzel
ROBERT J. WETZEL S1778





DOCUMENT

1538458

RECORDED
At Kenosha County, Kenosha, WI 53140
Louise L. Principe, Register of Deeds
on 10/31/2007 at 3:05PM
70052896 \$19.00

REGDEED3

JENF

PLAT OF SURVEY
-OF-

LOT 3 OF CERTIFIED SURVEY MAP NO. 2597, RECORDED AS DOCUMENT NO. 1538458 IN THE OFFICE OF THE REGISTER OF DEEDS IN AND FOR KENOSHA COUNTY, WISCONSIN AND BEING LOCATED IN PART OF THE NORTHWEST 1/4 OF THE SOUTHEAST 1/4 OF SECTION 6, TOWNSHIP 2 NORTH, RANGE 23 EAST OF THE FOURTH PRINCIPAL MERIDIAN, IN THE TOWN OF SOMERS, COUNTY OF KENOSHA AND STATE OF WISCONSIN.

SURVEY FOR: RUFFALO

LEGEND

- ⊕ FOUND BRASS CAPPED CONCRETE MONUMENT
- FOUND 3/4" O.D. IRON PIPE
- ⊘ FOUND 1" O.D. IRON PIPE
- ⊙ FOUND 3/4" DIA. IRON ROD
- FOUND 1-5/16" O.D. IRON PIPE
- ⊙ FOUND 2-3/8" O.D. IRON PIPE
- SET MASONRY NAIL IN ASPHALT DRIVE

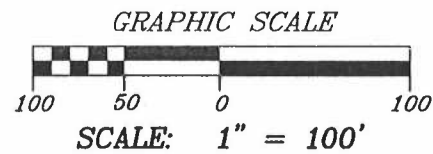

"I hereby certify that I have surveyed the above described property and that the above map is a correct representation thereof and shows the size and location of the property, its exterior boundaries, the location of all visible structures and dimensions of all principal buildings thereon, boundary fences, apparent easements, roadways and encroachments, if any."

"This survey is made for the use of the present owners of the property, and those who purchase, mortgage, or guarantee the title thereto within one year from date hereof."



B.W. SURVEYING, INC.

LAND SURVEYS
MAPPING AND PLANNING
412 N. PINE STREET
BURLINGTON, WI 53105
(262)-767-0225



WEST LINE OF THE SOUTHEAST 1/4 OF SECTION 6-2-23

13TH AVENUE
WIDTH VARIES

REFER TO A CURRENT TITLE REPORT FOR EASEMENTS AND RESTRICTIONS WHICH MAY AFFECT THE USE OF THIS SITE.

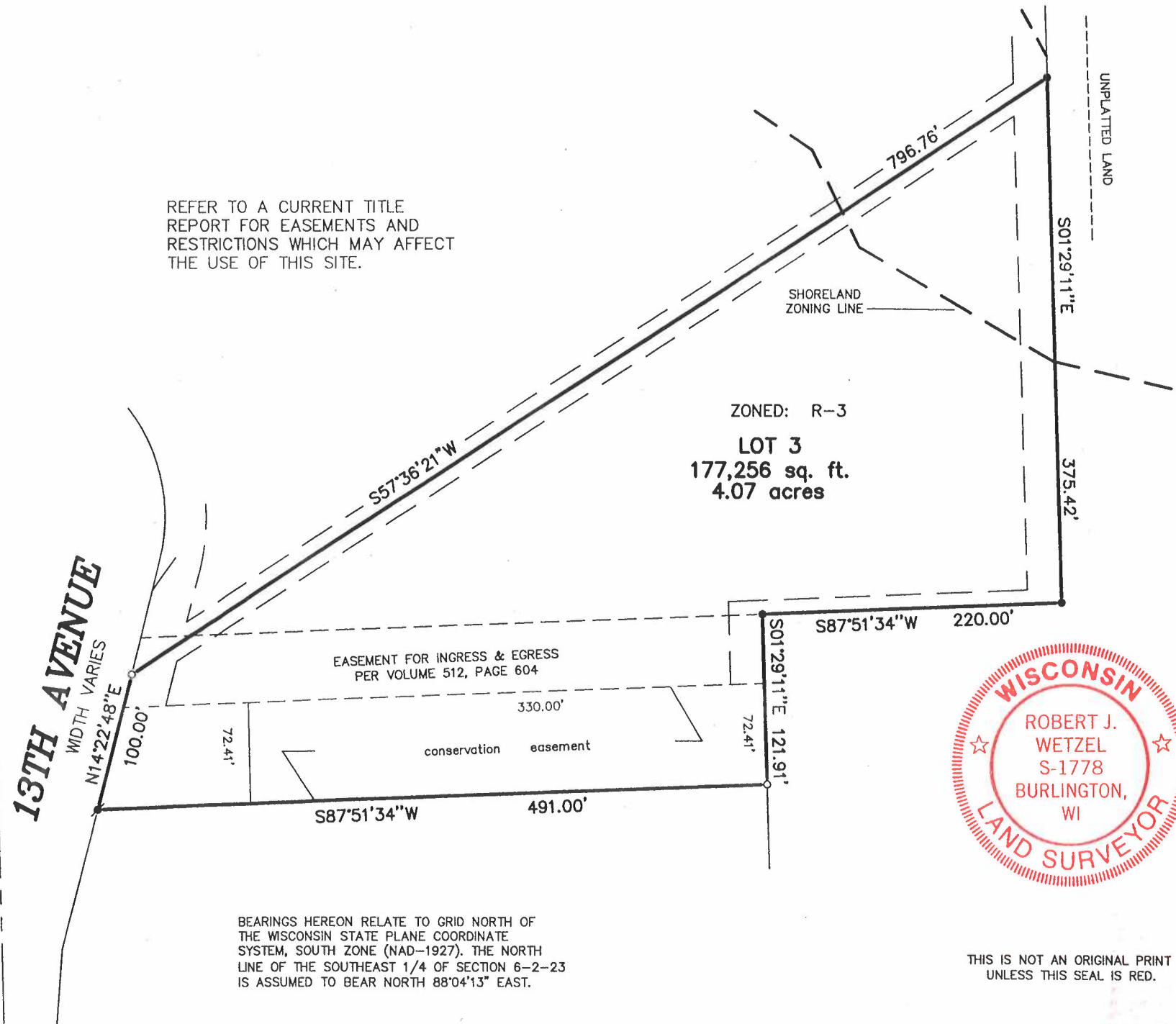

BEARINGS HEREON RELATE TO GRID NORTH OF THE WISCONSIN STATE PLANE COORDINATE SYSTEM, SOUTH ZONE (NAD-1927). THE NORTH LINE OF THE SOUTHEAST 1/4 OF SECTION 6-2-23 IS ASSUMED TO BEAR NORTH 88°04'13" EAST.



THIS IS NOT AN ORIGINAL PRINT UNLESS THIS SEAL IS RED.

Robert J. Wetzel
ROBERT J. WETZEL S-1778

AUGUST 17, 2020
DATE

7543-LOT 3
JOB NUMBER

83-4-223-064-0213

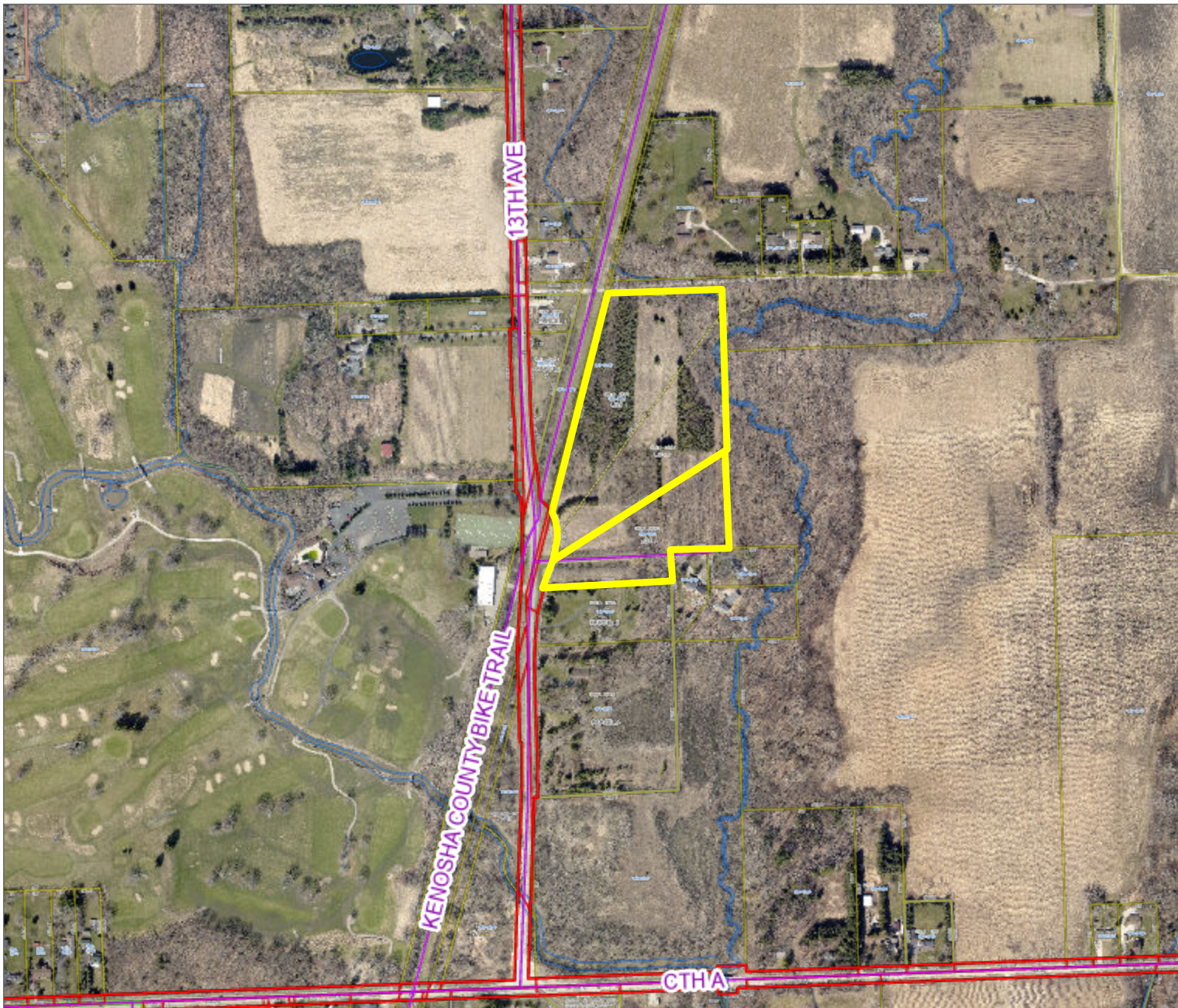

Legend



1 Inch = 570 Feet

Date Printed: 12/2/2022

DISCLAIMER This map is neither a legally recorded map nor a survey and is not intended to be used as one. This drawing is a compilation of records, data and information located in various state, county and municipal offices and other sources affecting the area shown and is to be used for reference purposes only. Kenosha County is not responsible for any inaccuracies herein contained. If discrepancies are found, please contact Kenosha County.



**VILLAGE OF SOMERS
VILLAGE BOARD
MEETING ITEM MEMORANDUM**

MEETING DATE: December 13th, 2022

TO: Village President Stoner and Village Trustees

PREPARED BY: Jason J. Peters, Administrator

AGENDA ITEM: #13 Action on Ordinance No. 2022-022, An Ordinance to Create Sections 7.03(E), (F), (G), (H) and (I) of the Code of Ordinance of the Village of Somers Regarding No Parking

BACKGROUND:

Public Works has requested the posting of 1st Way and 62nd Avenue, 28th Street and 113th Avenue, and 64th Avenue as “No Parking”. Attorney Davison has drafted the requisite ordinance to post these areas as “No Parking”

PRIOR ACTION TAKEN:

This matter was reviewed and discussed at our December 6th Work Session.

SUGGESTED ACTION/ACTION REQUESTED/COMMENTS:

Staff would recommend approval of proposed Ordinance 2022-022. In the event that the Village Board agrees with the suggested action, a suggested motion to approve would be as follows:

“Motion to waive first reading of Ordinance No. 2022-022”

“Motion to approve proposed Ordinance No. 2022-022, An Ordinance to Create Sections 7.03(E), (F), (G), (H) and (I) of the Code of Ordinance of the Village of Somers Regarding No Parking”

ATTACHMENTS:

Ordinance 2022-022

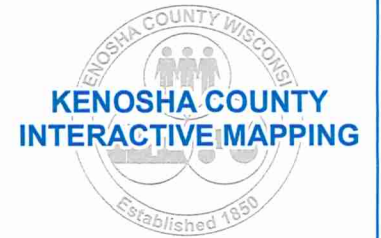
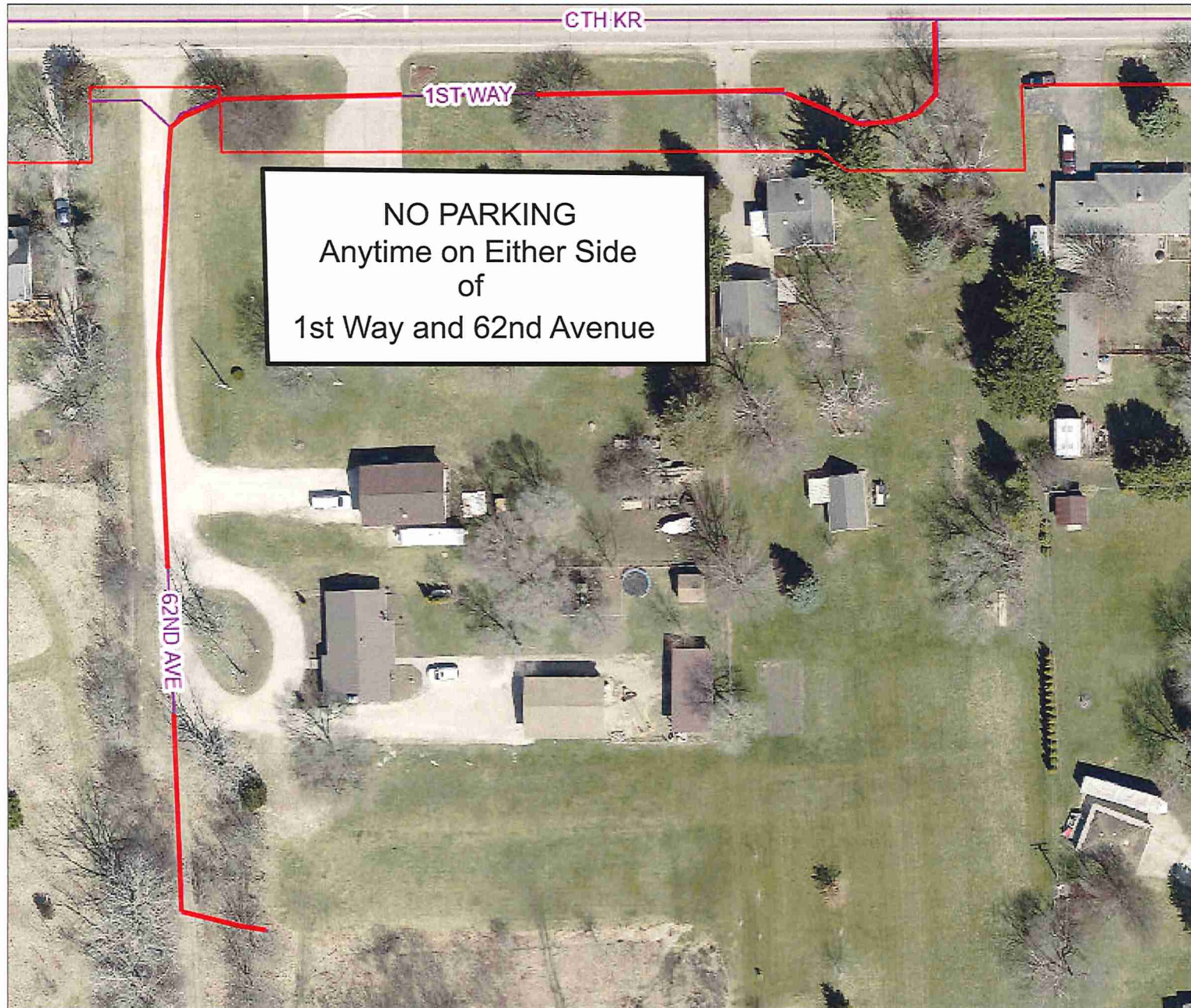

1 Inch =75 Feet

DISCLAIMER This map is neither a legally recorded map nor a survey and is not intended to be used as one. This drawing is a compilation of records, data and information located in various state, county and municipal offices and other sources affecting the area shown and is to be used for reference purposes only. Kenosha County is not responsible for any inaccuracies herein contained. If discrepancies are found, please contact Kenosha County.

Date Printed: 12/1/2022

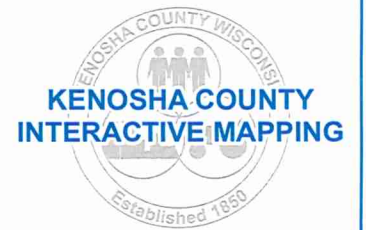

1 Inch =225 Feet

DISCLAIMER This map is neither a legally recorded map nor a survey and is not intended to be used as one. This drawing is a compilation of records, data and information located in various state, county and municipal offices and other sources affecting the area shown and is to be used for reference purposes only. Kenosha County is not responsible for any inaccuracies herein contained. If discrepancies are found, please contact Kenosha County.

Date Printed: 12/1/2022



NO PARKING
Anytime on Either Side
of
64th Avenue



1 Inch =56 Feet

DISCLAIMER This map is neither a legally recorded map nor a survey and is not intended to be used as one. This drawing is a compilation of records, data and information located in various state, county and municipal offices and other sources affecting the area shown and is to be used for reference purposes only. Kenosha County is not responsible for any inaccuracies herein contained. If discrepancies are found, please contact Kenosha County.

Date Printed: 12/1/2022

ORDINANCE NO. _____

AN ORDINANCE TO CREATE SECTIONS 7.03(E), (F), (G), (H) and (I)
OF THE CODE OF ORDINANCES OF THE VILLAGE OF SOMERS
REGARDING NO PARKING

The Village Board of Trustees of the Village of Somers, Kenosha County, Wisconsin, hereby creates Section 7.03(E), (F), (G), (H) and (I) of the Code of Ordinances of the Village of Somers to read as follows:

- (E) No parking on either side of 64th Avenue from 45th Street North to its termination.
- (F) No parking on either side of 1st Way from CTH "KR" to 62nd Avenue.
- (G) No parking on either side of 62nd Avenue from 1st Way to its termination.
- (H) No parking on either side of 28th Street from 120th Avenue to 113th Avenue.
- (I) No parking on either side of 113th Avenue from CTH "S" to its termination.

Dated at Somers, Wisconsin, this _____ day of _____, 202____.

VILLAGE OF SOMERS

By: _____
George Stoner, President

Attest: _____
Brandi Baker, Clerk/Treasurer

**VILLAGE OF SOMERS
VILLAGE BOARD
MEETING ITEM MEMORANDUM**

MEETING DATE: December 13th, 2022

TO: Village President Stoner and Village Trustees

PREPARED BY: Jason J. Peters, Administrator

AGENDA ITEM: #14 Discussion and possible action on adding a onetime stipend for new full-time employees who were hired between June 1st, 2022 and August 1st, 2022 in amount of \$1000 each.

BACKGROUND:

In May of 2022, the Board approved two stipends for full time employees. For the majority of the full-time employees, this equated to a \$1,000 payment the end of June and another at years end. The funds for these stipends came from the Village's allotted ARPA funds. Since this time two full time been hired by the Village. In recognition of their hard work since their hire, Administrator Peters has requested that they be added to the year end stipend payment. This will only add an additional \$1,000 to the amount that was budgeted for the allocation due to the number of staff members who previously received stipends was increased by one.

PRIOR ACTION TAKEN:

The possibility of putting this item on the agenda was discussed at our December 6th Work Session under the review of tentative agenda.

SUGGESTED ACTION/ACTION REQUESTED/COMMENTS:

Administrator Peters would recommend approval of adding a one stipend for new full time employees who were hired between June 1st, 2022 and August 1st, 2022, in amount of \$1000 each. In the event that the Village Board agrees with the suggested action, a suggested motion to approve would be as follows:

“Motion to approve adding a one stipend for new full-time employees who were hired between June 1st, 2022 and August 1st, 2022 in amount of \$1000 each.

ATTACHMENTS:

None



**VILLAGE OF SOMERS
VILLAGE BOARD
MEETING ITEM MEMORANDUM**

MEETING DATE: December 13, 2022

TO: Village President Stoner and Village Trustees

PREPARED BY: Brandi Baker, Clerk/Treasurer

AGENDA ITEM: #15 Action on recommendation to approve operator licenses for Jennifer Vander Loop

BACKGROUND:

Jennifer Vander Loop has applied for operators' licenses for the Village of Somers. No discrepancies with the applications.

PRIOR ACTION TAKEN:

None.

SUGGESTED ACTION/ACTION REQUESTED/COMMENTS:

Staff recommends approval. In the event that the Village Board agrees with the recommendation to approve applications, a suggested motion would be as follows:

“Motion to approve Operator Licenses: Jennifer Vander Loop”

ATTACHMENTS:

NONE